

FLEX MOUNT KIT INSTALLATION INSTRUCTIONS FMK-SW (Swing Gates) & FMK-SL (Sliding Gates)

Note: Securitron recommends welding all brackets and hardware after installation to ensure maximum security.

RECOMMENDED TOOLS

- | | | |
|-------------------|-------------------|---------------------------------|
| Electric Drill | 3/16" Hex Wrench | 5/16", 13/16" & 3/8" Drill Bits |
| Adjustable Wrench | 1/4"-20 Tap | 7/16" Socket Wrench |
| Hammer | Welder (optional) | Center Punch |

1. PRODUCT OVERVIEW

Upon unpacking this product, an inventory should be made to ensure that all the required components and hardware have been included. Along with these instructions each product should include the following items.

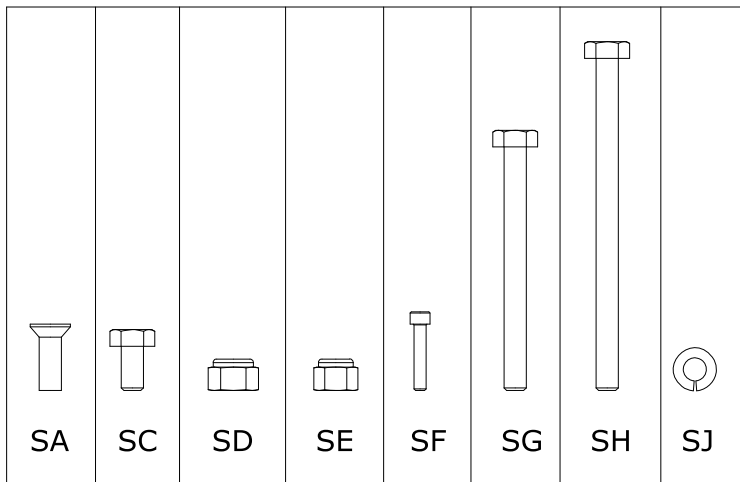

FASTENER	QTY	DESCRIPTION
SA	1	5/16-18 X 1 1/4 FH SCREW
SC	6	1/4-20 X 1/2" HEX BOLT
SD	1	5/16-18 LOCK NUT
SE	4	1/4-20 LOCK NUT
SF	4	1/4-20 X 1-3/4" CAP SCREW
SG	2	1/4-20 X 2-3/4" HEX BOLT
SH	2	1/4-20 X 3-3/4" HEX BOLT
SJ	6	1/4" SPLIT WASHER

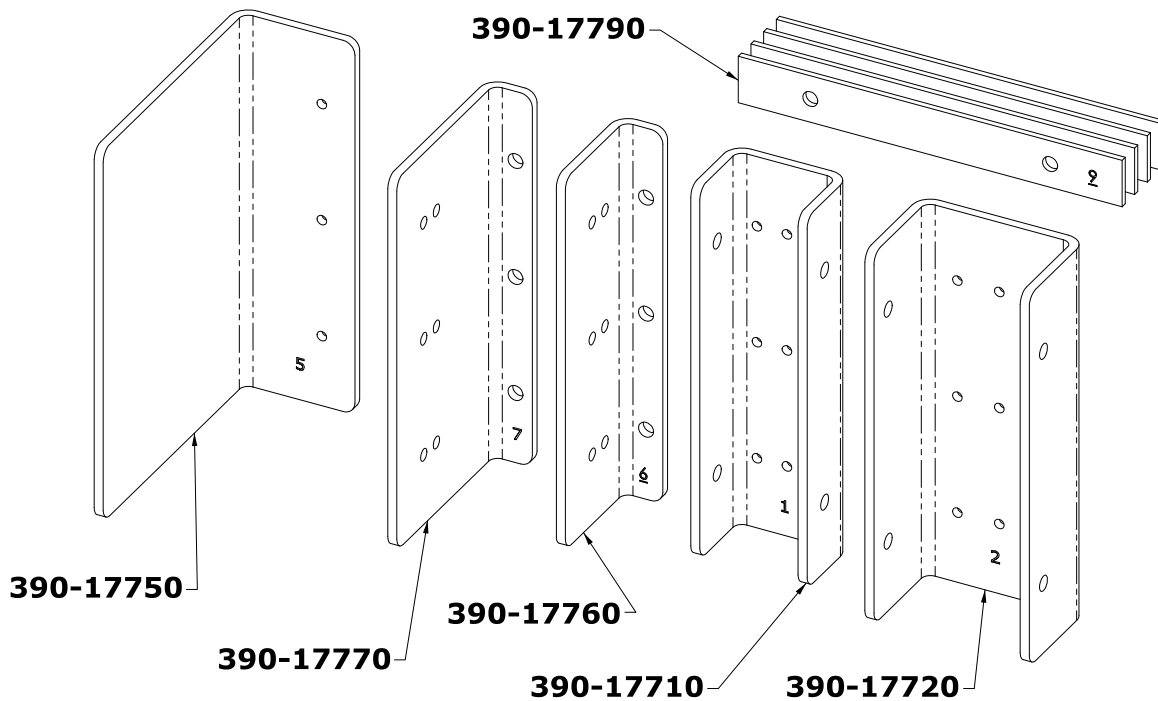

FMK-SW - Swing Gate Kit

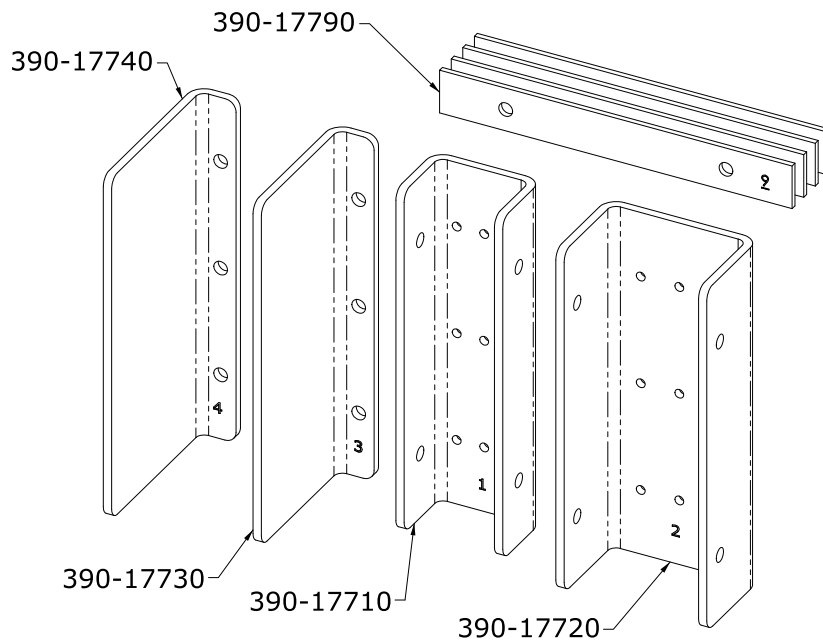

FMK-SL – Slide Gate Kit

2. SWINGING GATES - INSTALLATION INSTRUCTIONS

Pre-Installation Survey

It is recommended that an initial on sight survey be performed. A method of mounting should be determined and an installation plan should be reviewed as follows:

- Physical strength of mounting areas should be strong enough to meet or exceed the holding force of the required Magnalock.
- Placement of the Magnalock wiring and protection from potential damage due to intruders or vandals external attack should be considered during the survey.
- Accessibility should be considered for prevention of any potential safety hazard.

Swinging Gate Applications

Installing the lock “U” Bracket (#2) to the fence post

The installation must be planned before you start drilling. The bracket must first be positioned on the fence post (see **FIG 1**) at a location suitable for lock height, Make sure there are no obstructions on either the fence or gate posts at this height, using the bracket as a template, carefully mark the four through hole locations onto the post.

Remove the bracket and carefully center punch and drill the four locations using a 5/16" drill bit, reinstall the bracket and install the shims and hardware as shown in **FIG 1**.

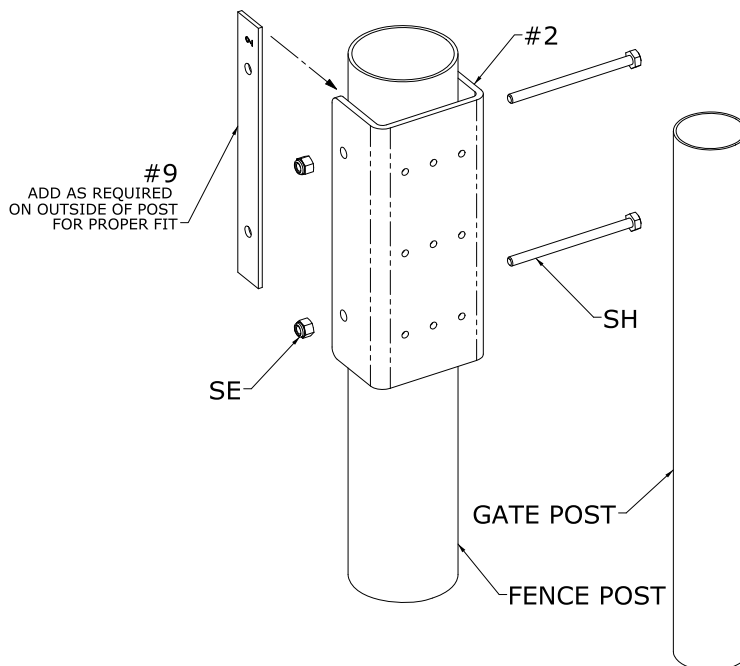

FIG 1

Installing the Lock

GL1 - Position the lock template onto Bracket #2, align the lower holes of the template with the lowest holes in the bracket and mark the two upper holes for the GL1. Carefully center punch and drill the two new holes with a 13/64" bit and tap for 1/4-20 machine screws. Install the lock using the hardware as shown in **FIG 2A** . Install GL1 chassis with indicated hardware in the upper holes. Complete installation of the GL1 lock by referring to FIG 2A and following the installation guide included with the GL1.

Magnalock® - Position the lock template onto Bracket #2, mark only the four corner holes for the Magnalock. Carefully center punch and drill all four holes with a 13/64" bit and tap for 1/4-20 machine screws. Install the lock using the hardware as shown in **FIG 2B**. Complete installation of the Magnalock lock by referring to **FIG 2B** and following the installation guide included with the Magnalock.

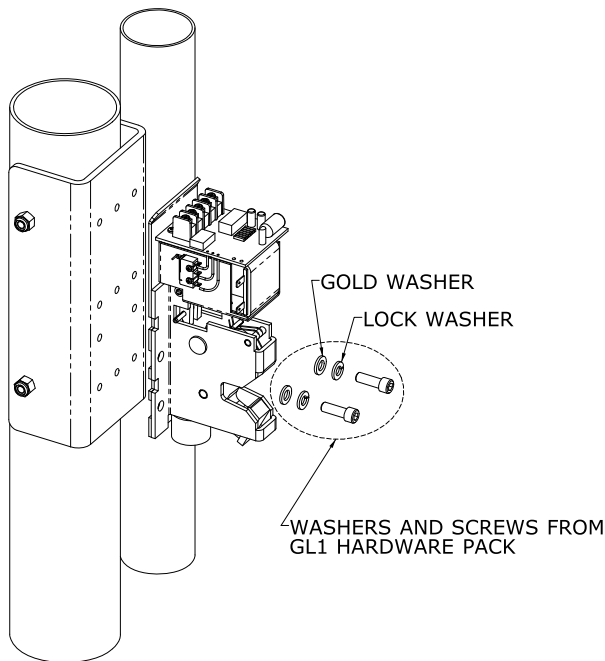

FIG 2A

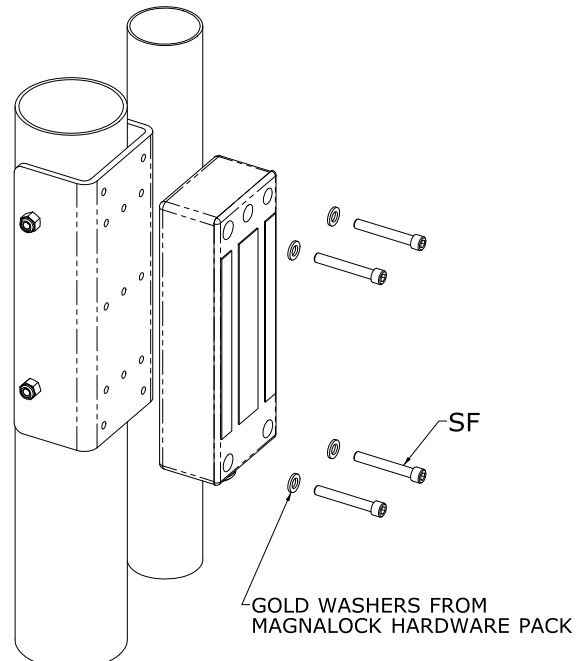

FIG 2B

Installing the GL1 strike "U" Bracket (#1) to the gate post

Close the gate and align the GL1 strike bracket on the fence post to match the position of the lock bracket as shown in **FIG 3**, using the bracket as a template, carefully mark the four through-hole locations onto the post.

Remove the bracket and carefully center punch and drill the four locations using a 5/16" bit, reinstall the bracket and install the shims and hardware as shown in **FIG 3**.

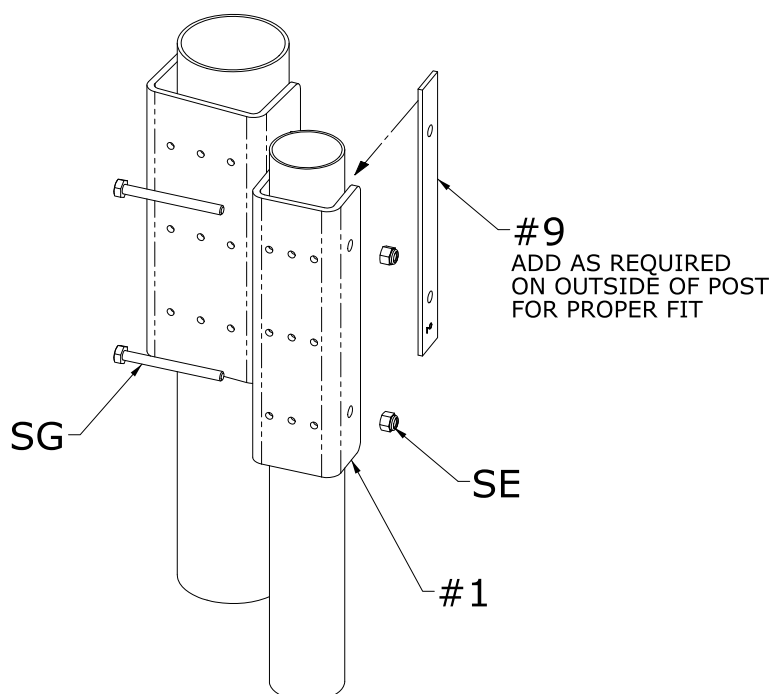

FIG 3

Installing the adjustable Z-Bracket assembly

Select the appropriate "L" bracket for your application (#6 for Magnalocks, #7 for GL1 or Magnalock with SASM) adjust and install bracket #5 as shown in FIG 4A & 4B, adjust and install completed Z-Bracket as shown in FIG 4A & 4B. Note: Brackets can be adjusted in any manner necessary to cover the lock area as shown in FIG 4A & 4B.

Installing the strike assembly to the Z-Bracket

Position the strike to the lock, ensure it is aligned properly with the lock (you can energize the Magnalock to hold the strike or insert the GL1 strike into the latch for ease of alignment) carefully close the gate and Z-Bracket until it touches the strike. Mark the outer edge outline of the strike, open the gate and position the strike template in the outlined area. Mark the mounting and roll pin hole locations as needed, center punch and drill appropriate holes (13/64" drill bit and 1/4-20 tap for GL1 strike, or 5/16" drill bit for Magnalock strike center hole and roll pins, attach as shown in FIG 4A & 4B.

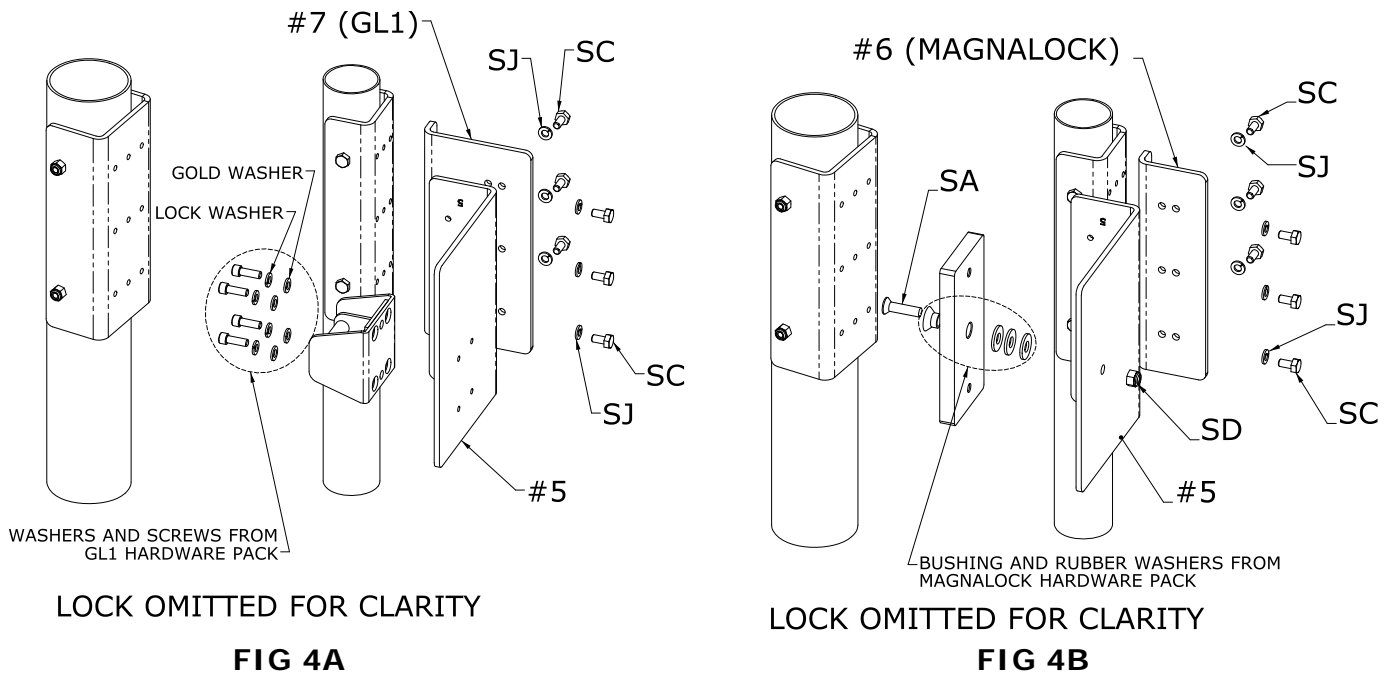

3. SLIDING GATES - INSTALLATION INSTRUCTIONS

Pre-Installation Survey

It is recommended that an initial on sight survey be performed. A method of mounting should be determined and an installation plan should be reviewed as follows:

- Physical strength of mounting areas should be strong enough to meet or exceed the holding force of the required Magnalock.
- Placement of the Magnalock wiring and protection from potential damage due to intruders or vandals external attack should be considered during the survey.
- Accessibility should be considered for prevention of any potential safety hazard.

Sliding Gate Applications

Installing the lock "U" Bracket (#2) to the fence post

The installation must be planned before you start drilling. The bracket must first be positioned on the fence post (see FIG 5) at a location suitable for lock height, Make sure there are no obstructions on either the fence or gate posts at this height, using the bracket as a template, carefully mark the four through hole locations onto the post.

Remove the bracket and carefully center punch and drill the four locations using a 5/16" bit, reinstall the bracket and install the shims and hardware as shown in FIG 5.

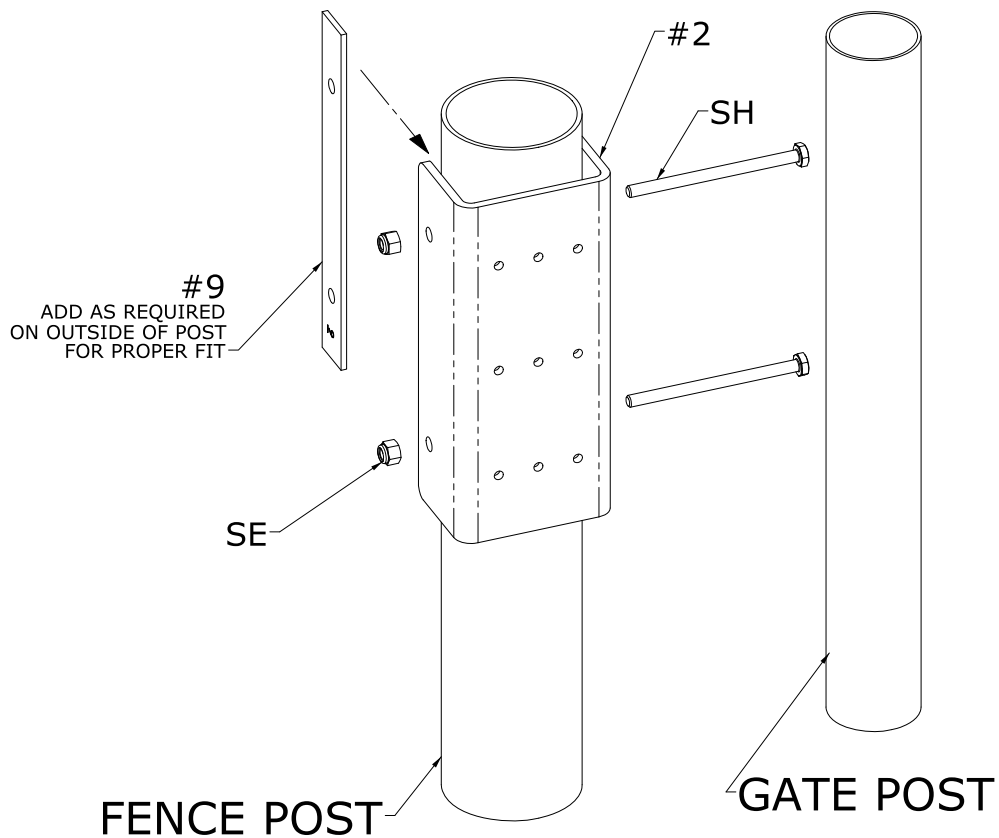

FIG 5

Installing the lock "L" Bracket and lock

Adjust the lock "L" bracket (#3) as shown in FIG 6, note: bracket #3 can be adjusted in any manner necessary to locate the lock as needed for proper gate closure.

GL1 - Position the lock template onto Bracket #3, mark the four mounting holes for the GL1 and center wire feed hole if required. Carefully center punch and drill the four mounting holes with a 13/64" bit and tap for 1/4-20 machine screws. Install the lock using the hardware as shown in FIG 6A. Install GL1 chassis with indicated hardware in the upper holes. Complete installation of the GL1 lock by referring to FIG 6A and following the installation guide included with the GL1.

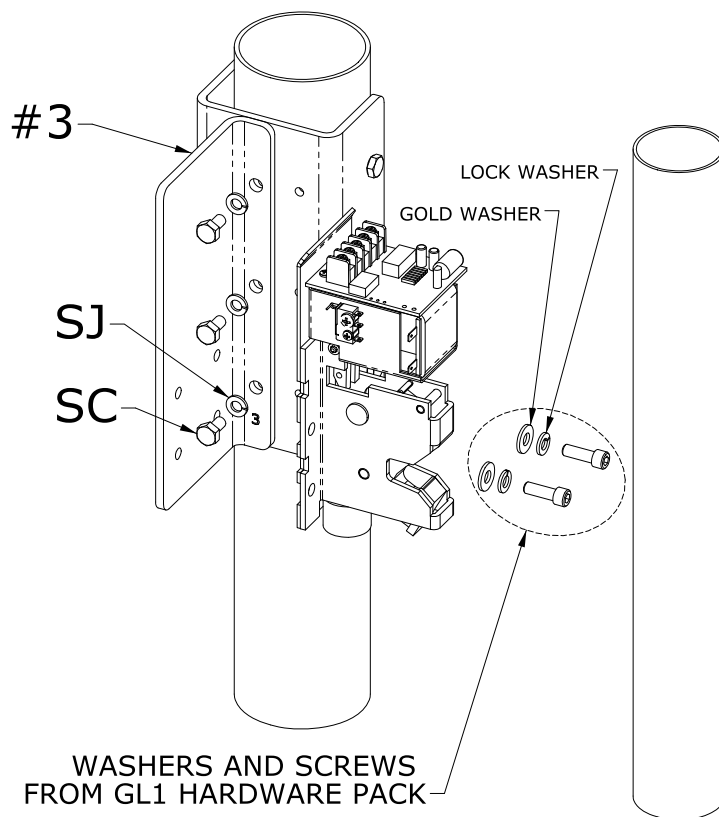

FIG 6A

Magnalock® - Position the lock template onto Bracket #3, mark only the four corner holes for the Magnalock. Carefully center punch and drill all four holes with a 13/64" bit and tap for 1/4-20 machine screws. Install the lock using the hardware as shown in **FIG 6B**. Complete installation of the Magnalock lock by referring to **FIG 6B** and following the installation guide included with the Magnalock.

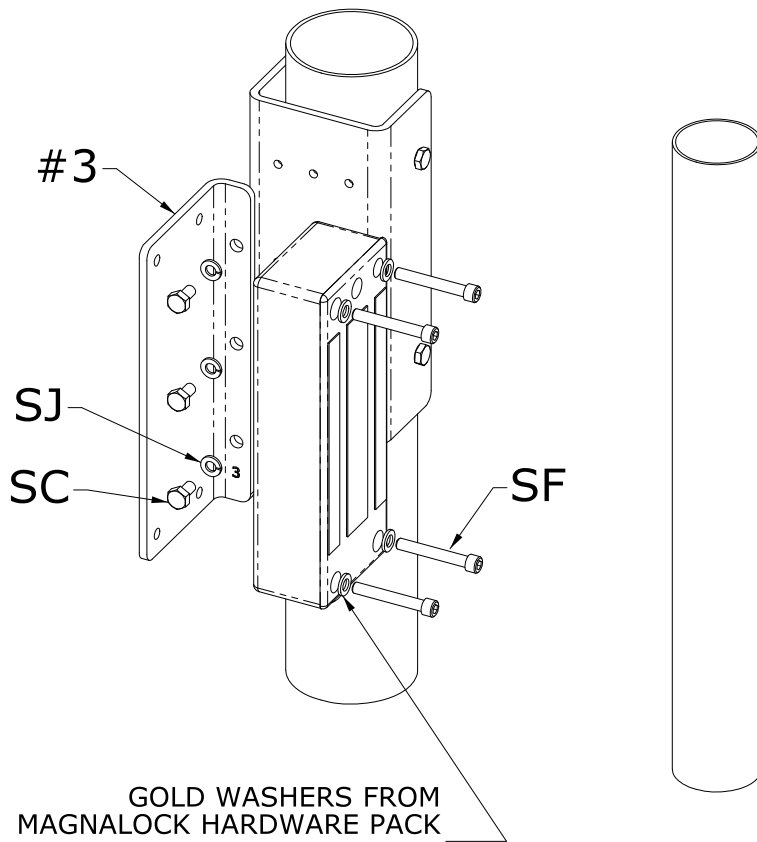
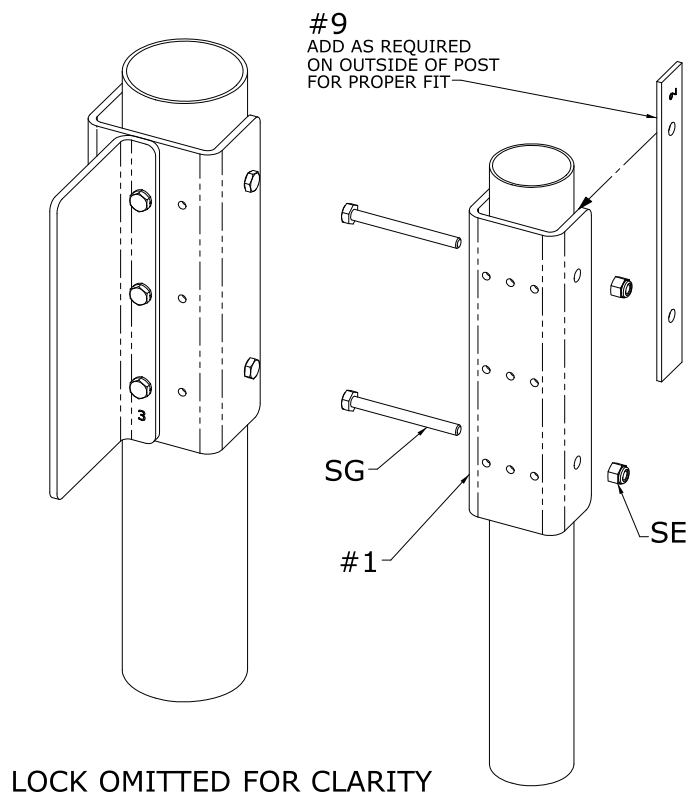

FIG 6B

Installing the strike "U" Bracket (#1) to the gate post

Close the gate and align the strike bracket on the fence post to match the position of the lock bracket as shown in **FIG 7**, using the bracket as a template, carefully mark the four through-hole locations onto the post.

Remove the bracket and carefully center punch and drill the four locations using a 5/16" bit, reinstall the bracket and install the shims and hardware as shown in **FIG 7**.



LOCK OMITTED FOR CLARITY

FIG 7

Installing the strike "L" Bracket and strike

Adjust the lock "L" bracket (#4) as shown in **FIG 8A** & **8B**. NOTE: Bracket #4 can be adjusted in any manner necessary to locate the strike as needed for proper gate closure. Position the strike to the lock, ensure it is aligned properly with the lock (you can energize the Magnalock to hold the strike or insert the GL1 strike into the latch for ease of alignment) carefully close the gate and Z bracket until it touches the strike. Mark the outer edge outline of the strike, open the gate and position the strike template in the outlined area. Mark the mounting and roll pin hole locations as needed, center punch and drill appropriate holes (13/64" drill bit and 1/4-20 tap for GL1 strike, or 5/16" for Magnalock strike center hole and roll pins), attach as shown in **FIG 8A** & **8B**.

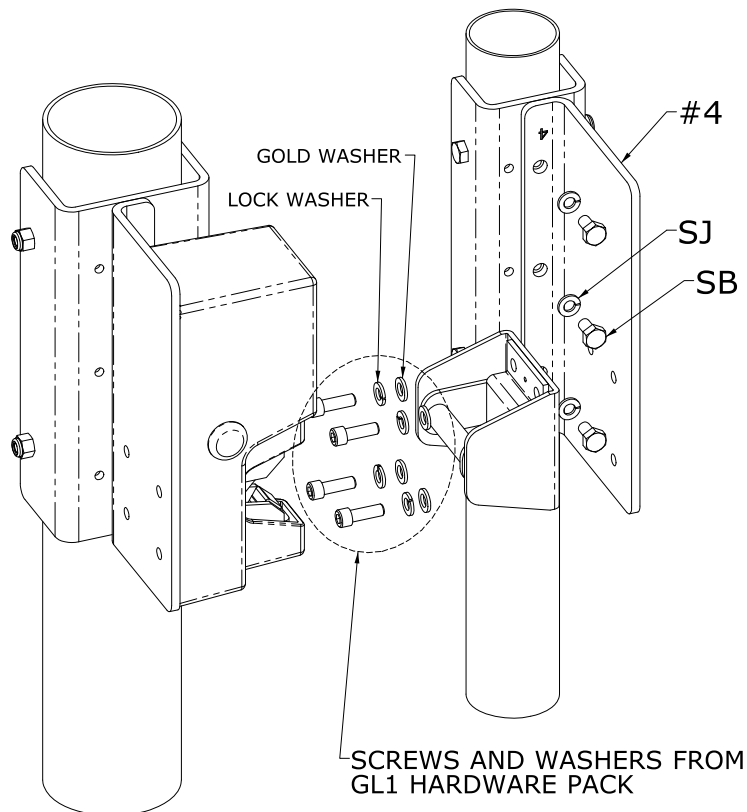

FIG 8A

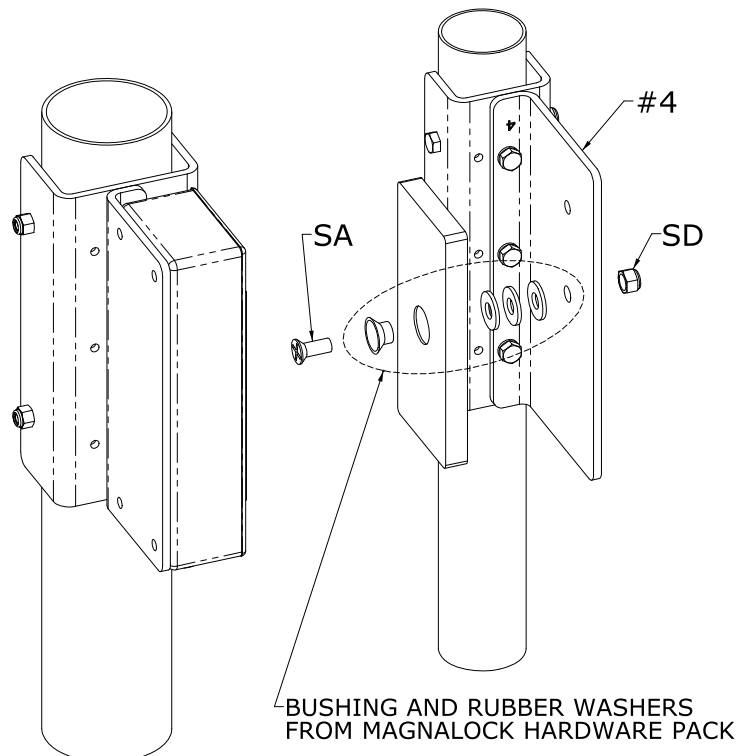

FIG 8B

MAGNACARE® LIFETIME REPLACEMENT WARRANTY

For warranty information visit www.securitron.com/en/site/securitron/About/MagnaCare-Warranty