

# DIY RFID RS232 / RS485 Computer Access Controller

KS232DU	KS485DU	KS232DF	KS485DF
---------	---------	---------	---------

***Computer based cost effective solutions for access control with Time Recorder***

## Quick Start:

1. For KS232D series products - connect the RS232 cable (straight through) from the computer to the terminal block of RS232 port. (See Terminal Layout)

For KS485D series products - plug the KC485C (buy separately) into the serial port of the computer. Connect the terminal block of KC485C to the RS485 data bus of the reader. (See Terminal Layout)

2. Connect a 9 to 12VDC supply to the terminal block of 9-12V 300mA.

3. Turn on the computer.

4. Insert the Time Recorder CD into your computer's CD-ROM drive. The Installer will start by itself automatically. If the Installer doesn't start automatically, you can run the setup.exe program to install the software.

5. Follow the installation instruction to finish the installation and follow the Installation Manual of Time Recorder from *Start* for details of Time Recorder's Setup.

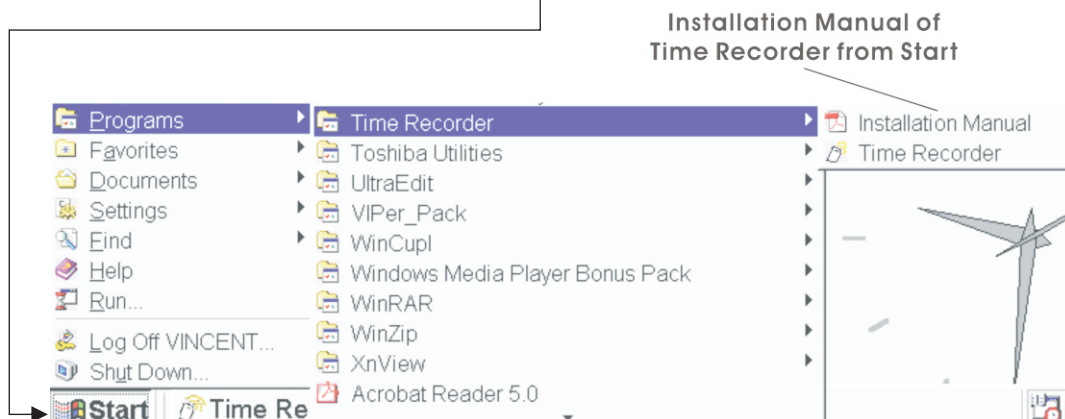

## Time Recorder Quick Start

1. Setup the RFID Readers
2. Setup the EMAIL Settings
3. Webcam Setup

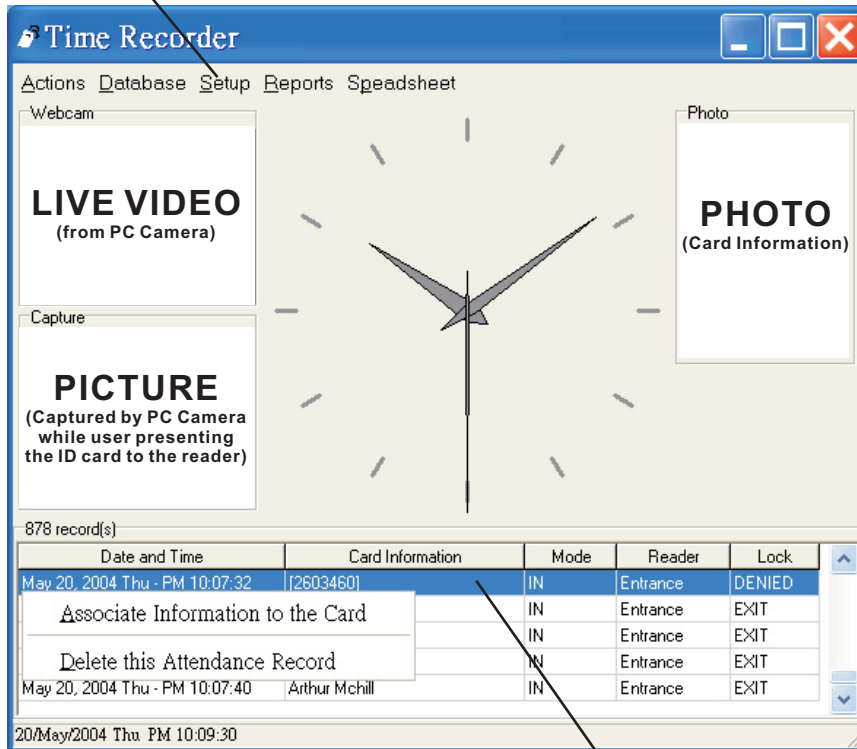

4. Present the ID cards to the reader.
5. Double click the record to enter Card Information.  
Or, Edit Card Information in Setup
6. Start and enjoy the Time Recorder.

*For details, please check the Installation Manual or email us at [support@avea.cc](mailto:support@avea.cc) for support.*

## LED and Buzzer Indication

INDICATION	RED LED	GREEN LED	BUZZER	LOCK
Stand by mode – waiting for instruction	Blink			
Action: Present a card to the reader				
The reader is not connected to the computer	ON			
ID card with NO Card Information	ON		ON	
ID card with Card Information	ON	ON	ON	
ID card with Card Information and access allowed	ON	ON	ON	RELEASE

# KS232DU / KS485DU / KS232DF / KS485DF RFID Computer Access Controller and Time Recorder

## INTRODUCTION

The KS232DU / KS485DU / KS232DF and KS485DF proximity readers are cost effective solutions for access control and time recording solutions. While connecting them to the computer and running the Time Recorder software (in Windows), the program will stamp the date, time and card ID into the computer database, show up the associated picture with the specific ID on the computer screen, capture the photo if a PC camera is connected to the computer and release the electric lock if allow access.

A 9 to 12V DC supply is required to power the reader, which has a current consumption of less than 300mA.

## TERMINAL LAYOUT

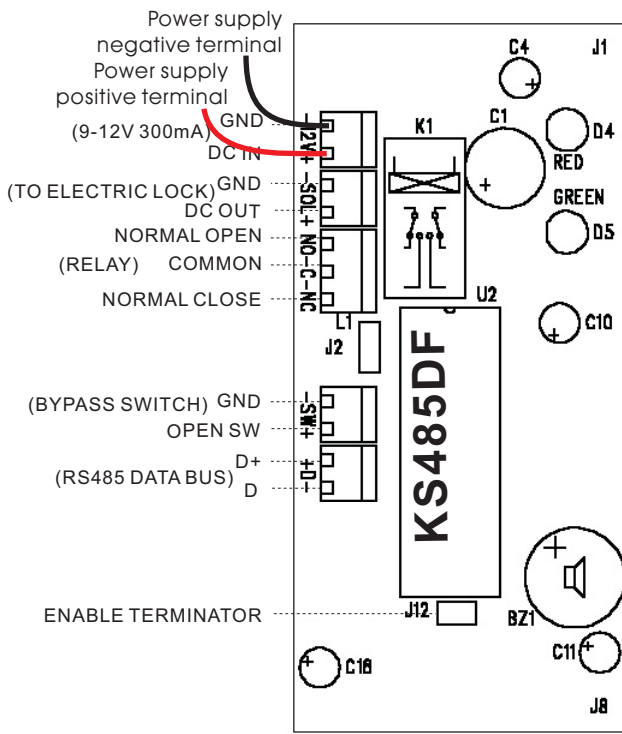

**MODEL KS485DF**

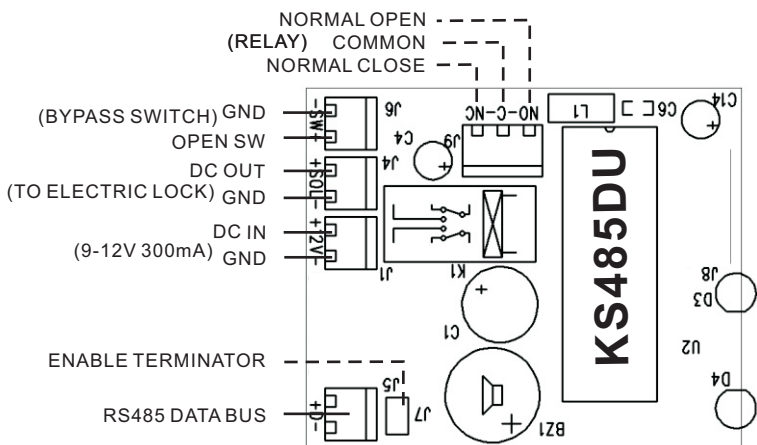

**MODEL KS485DU**

## MODEL KS232DU

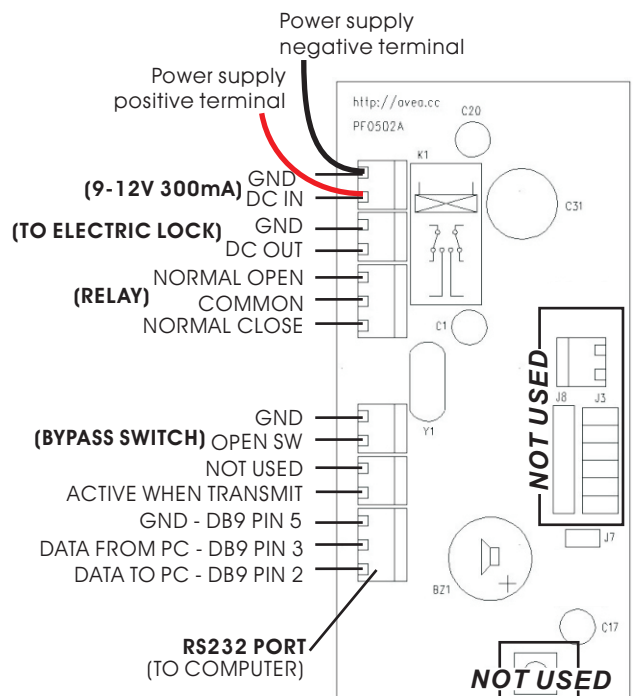
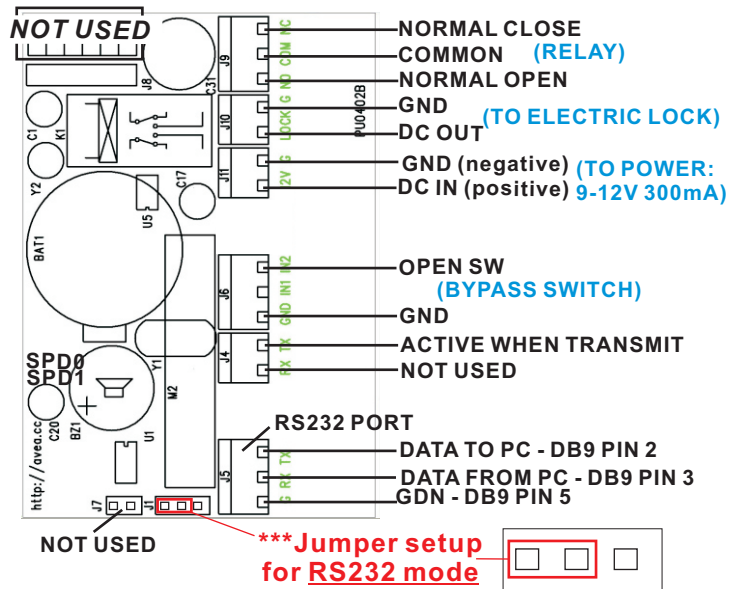

**MODEL KS232DF**

## KS232DF and KS485DF Dimensions:

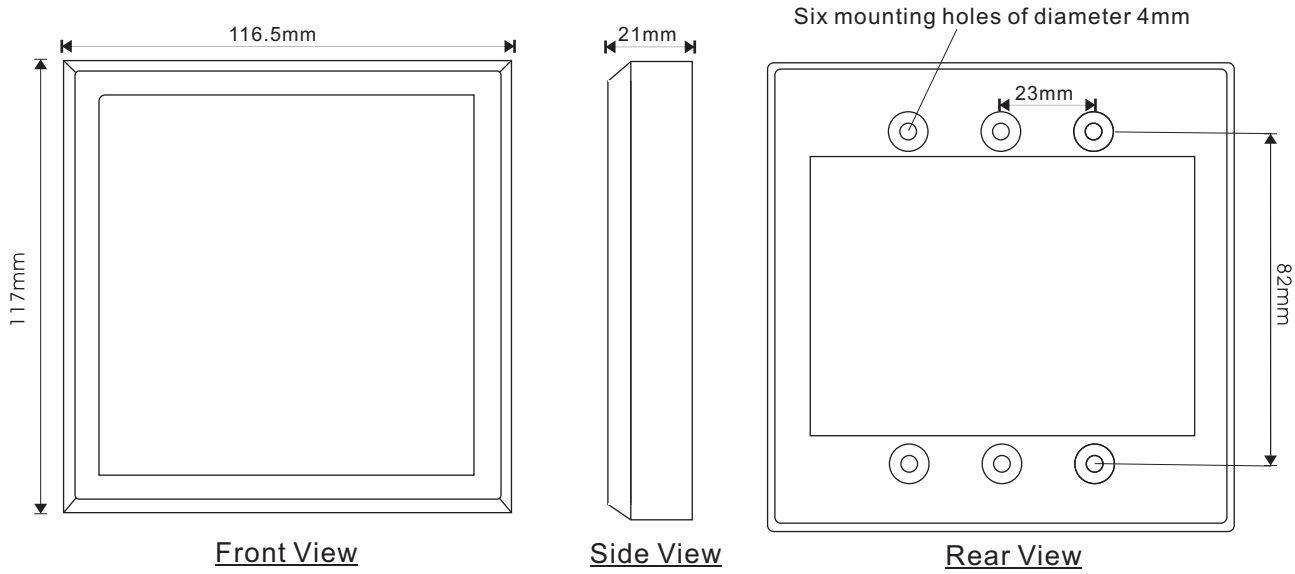

## KS232DU and KS485DU Dimensions:

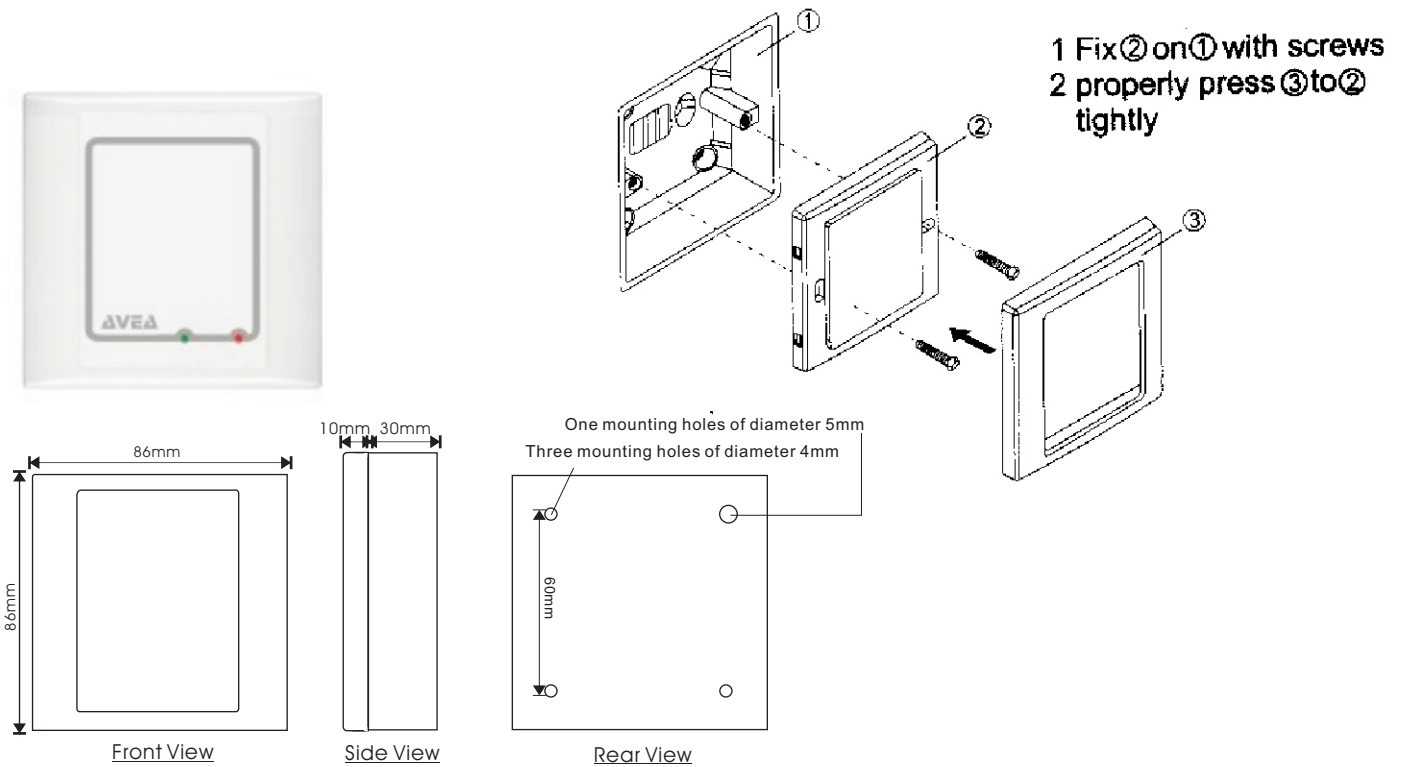

## LOCK CONNECTION:

