

PARTS, OPERATION AND MAINTENANCE MANUAL for LEVER CHAIN HOIST MODELS

Roughneck™

L5H150

3/4 ton (metric)

L5H200

1 ton (metric)

L5H300

1-1/2 ton (metric)

L5H400

2 ton (metric)

L5H600

3 ton (metric)

L5H1200

6 ton (metric)

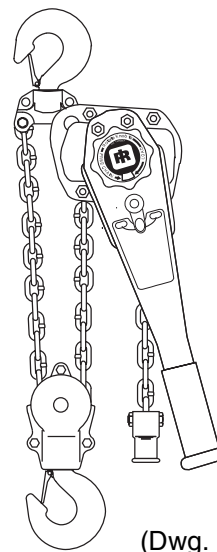
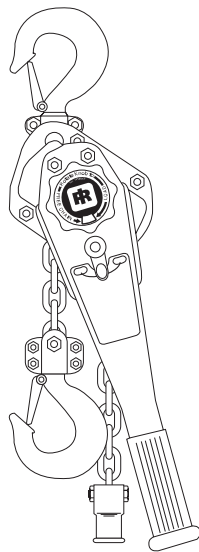

1 US ton = 2,000 lbs.
1 metric ton = 2,200 lbs.

(Dwg. MHP1076)

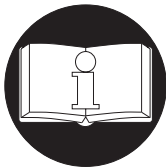

READ THIS MANUAL BEFORE USING THESE PRODUCTS. This manual contains important safety, installation, operation and maintenance information. Make this manual available to all persons responsible for the installation, operation and maintenance of these products.

! WARNING

Do not use this hoist for lifting, supporting, or transporting people or lifting or supporting loads over people.

Always operate, inspect and maintain this hoist in accordance with American National Standards Institute Safety Code (ASME B30.21) and any other applicable safety codes and regulations.

SAFETY INFORMATION

This manual provides important information for all personnel involved with the safe installation, operation and proper maintenance of this product. Even if you feel you are familiar with this or similar equipment, you should read this manual before operating the product.

Danger, Warning, Caution and Notice

Throughout this manual there are steps and procedures which, if not followed, may result in a hazard. The following signal words are used to identify the level of potential hazard.

⚠ DANGER Danger is used to indicate the presence of a hazard which *will* cause *severe* injury, death, or substantial property damage if the warning is ignored.

⚠ WARNING Warning is used to indicate the presence of a hazard which *can* cause *severe* injury, death, or substantial property damage if the warning is ignored.

⚠ CAUTION Caution is used to indicate the presence of a hazard which *will* or *can* cause injury or property damage if the warning is ignored.

NOTICE Notice is used to notify people of installation, operation, or maintenance information which is important but not hazard-related.

Safety Summary

⚠ WARNING

- Do not use this hoist for lifting, supporting, or transporting people or lifting or supporting loads over people.
- Hoists are designed to provide a 4 to 1 safety factor. Supporting structures and load-attaching devices used in conjunction with this hoist must provide an adequate safety factor to handle the rated load, plus the weight of the hoist and attached equipment. This is the customer's responsibility. If in doubt, consult a registered structural engineer.

Ingersoll-Rand hoists are manufactured in accordance with the latest ASME B30.21 standards.

The National Safety Council, Accident Prevention Manual for Industrial Operations, Eighth Edition and other recognized safety sources make a common point: Employees who work near cranes or assist in hooking on or arranging a load should be instructed to keep out from under the load. From a safety standpoint, one factor is paramount: conduct all lifting operations in such a manner that if there were an equipment failure, no personnel would be injured. This means keep out from under a raised load and keep out of the line of force of any load.

The Occupational Safety and Health Act of 1970 generally places the burden of compliance with the user, not the manufacturer. Many OSHA requirements are not concerned or connected with the manufactured product but are, rather, connected with the final installation. It is the owner's and user's responsibility to determine the suitability of a product for any particular use. It is recommended that all applicable industry, trade association, federal, state and local regulations be checked. Read all operating instructions and warnings before operation.

Rigging: It is the responsibility of the operator to exercise caution, use common sense and be familiar with proper rigging techniques. Refer to ASME B30.9 for rigging information, American National Standards Institute, 1430 Broadway, New York, NY 10018.

WARNING TAG

Each hoist is supplied from the factory with the warning tag shown. If tag is not attached to your unit, order a new tag and install it. Refer to the parts list for the part number. Read and obey all warnings and other safety information attached to this hoist. Tag may be shown smaller than actual size.

⚠ WARNING

Failure to follow these warnings may result in death, severe injury or property damage:

- Do not operate this hoist before reading operation and maintenance manual.
- Do not lift more than rated load.
- Do not lift people or loads over people.
- Do not operate hoist with twisted, kinked or damaged chain.
- Do not operate a damaged or malfunctioning hoist.
- Do not operate when chain cannot form straight line with load.
- Do not operate lever hoist with handle extension.
- Do not operate hoist with other than manual power.
- Do not remove or obscure warning labels.



SAFE OPERATING INSTRUCTIONS

The following warnings and operating instructions have been adapted in part from American National Standard ASME B30.21 and are intended to avoid unsafe operating practices which might lead to personal injury or property damage. These recommendations apply to hoists used for material handling of freely suspended unguided loads.

Ingersoll-Rand recognizes that most companies who use hoists have a safety program in force in their plants. In the event that some conflict exists between a rule set forth in this publication and a similar rule already set by an individual company, the more stringent of the two should take precedence.

Safe Operating Instructions are provided to make an operator aware of dangerous practices to avoid and are not necessarily limited to the following list. Refer to specific sections in the manual for additional safety information.

1. Only allow personnel trained in safety and operation to operate the hoist.
2. Only operate a hoist if you are physically fit to do so.
3. When a **“DO NOT OPERATE”** sign is placed on hoist, do not operate hoist until sign has been removed by designated personnel.
4. Before each shift, the operator should inspect hoist for wear or damage.
5. Never use a hoist which inspection indicates is worn or damaged.
6. Periodically, inspect hoist thoroughly and replace worn or damaged parts. Refer to **“INSPECTION”** section.
7. Lubricate hoist regularly. Refer to **“LUBRICATION”** section.
8. Do not use hoist if hook latch has been sprung or broken.
9. Check that hook latches are engaged before using.
10. Never splice a hoist chain by inserting a bolt between links.
11. Only lift loads less than or equal to rated capacity of hoist. Refer to **“SPECIFICATIONS”** section.
12. Never use hoist chain as a sling.
13. Never operate a hoist when load is not centered under top hook. Do not **“side pull”** or **“yard.”**
14. Never operate a hoist with twisted, kinked, **“capsized”** or damaged load chain.
15. Do not force a chain or hook into place by hammering.
16. Never insert point of hook into a chain link.
17. Be certain load is properly seated in saddle of hook, and hook latch is engaged.
18. Do not support load on tip of hook.
19. Never run load chain over a sharp edge. Use a sheave.
20. When using two hoists to suspend one load, select two hoists both having rated capacities equal to or more than the load to be lifted. This provides adequate safety in the event of a sudden load shift.
21. Pay attention to the load at all times when operating hoist.
22. Always ensure that you, and all other people, are clear of load path. Do not lift a load over people.
23. Never use hoist for lifting or lowering people, and never allow anyone to stand on a suspended load.
24. Ease slack out of chain and sling when starting a lift. Do not jerk load.
25. Do not swing a suspended load.
26. Do not leave a load suspended when hoist is unattended or not in use.
27. Never weld or cut a load suspended by the hoist.
28. Never use hoist chain as a welding electrode.
29. Do not operate hoist if chain jumping, excessive noise, jamming, overloading, or binding occurs.
30. Keep load from hitting load chain.
31. Do not use a cheater bar or extended handle.
32. After use, or when in a non-operational mode, hoist should be secured against unauthorized and unwarranted use.

SPECIFICATIONS

The L5H Lever Chain Hoist can be mounted to the suspension shaft of a trolley or a permanent mounting structure. The hoist is designed to lift and lower loads up to rated capacity with minimal lever effort.

To determine your hoist configuration refer to capacity and serial number nameplate for serial and model number information.

Model Code Explanation

Model Code Example: L5H300-15N

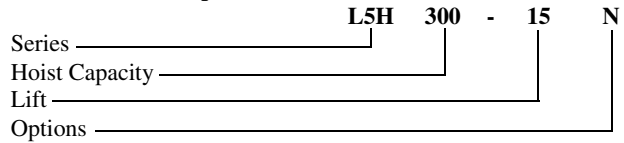

Series	Hoist Capacity	Lift	Options
L5H	150 = 3/4 metric ton (1,650 lbs. / 750 kg) 200 = 1 US ton (2,000 lbs. / 900 kg) 300 = 1.5 metric tons (3,300 lbs. / 1,500 kg) 400 = 2 US tons (4,000 lbs. / 1,800 kg) 600 = 3 metric tons (6,600 lbs. / 3,000 kg) 1200 = 6 metric tons (13,200 lbs. / 6,000 kg)	5 = 5 feet (1.5 metres) 10 = 10 feet (3 metres) 15 = 15 feet (4.5 metres) 20 = 20 feet (6 metres) XX = Specify length F = Hoist without chain	N = Nickel Diffused Load Chain V = Overload Limit Clutch Z = Zinc Plated Load Chain * - E = Meets European Machinery Directives

* L5H hoists sold in Europe furnished standard with zinc plated load chain. Zinc plated load chain not available in USA.

Model No.	Capacity - tons*		Pull to lift rated load		Load Chain size (mm)	Wt. of chain per 1 ft (0.3 m) of lift		No. of chain falls	Hoist Net Weight **	
	metric	US	lb	kg		lb	kg		lb	kg
L5H150	3/4	—	35	16	6.3 x 19.2	0.57	0.26	1	15	6.8
L5H200	—	1	43	20					16	7.3
L5H300	1-1/2	—	40	18					21	9.5
L5H400	—	2	49	23	7.1 x 21.2	0.74	0.34		22	10
L5H600	3	—	73	33					34	15.4
L5H1200	6	—	77	35	9 x 27.2	2.38	1.08		2	62

* 1 metric ton = 1000 kg/2200 lbs. 1 US ton = 2000 lbs/907 kg.

** Net weight based on hoist with 5 ft. (1.52 m) of lift.

INSTALLATION

Installation

Prior to installing hoist, carefully inspect it for possible shipping damage.

Hoists are supplied fully lubricated from the factory. Lubrication of the load chain is required before initial hoist operation.

⚠ CAUTION

• Owners and users are advised to examine specific, local or other regulations, including American National Standards Institute and/or OSHA Regulations, which may apply to a particular type of use of this product, before installing or putting hoist to use.

The L5H lever chain hoist can be used in any position provided it is rigged to pull in a straight line from top to bottom hook. The hoist must be positioned so that it does not contact the load or support members when in use. Ensure hand lever movement is unrestricted.

When operating in limited areas suitable lifting attachments or slings must be used to prevent frame and hand lever from being obstructed.

⚠ CAUTION

• Ensure hoist top hook is properly installed on support member.

Familiarize operators and personnel responsible for hoist installation and service with ASME B30.21 specifications prior to placing unit into service. All requirements of this specification, including testing should be met before approving hoist for operation.

OPERATION

Operation

The four most important aspects of hoist operation are:

1. Follow all safety instructions when operating hoist.
2. Allow only personnel trained in safety and operation of this hoist to operate hoist.
3. Subject each hoist to a regular inspection and maintenance procedure.
4. Be aware of hoist capacity and weight of load at all times.

⚠ WARNING

- **Hoist is not designed or suitable for lifting, lowering or moving personnel. Never lift loads over people.**
- **Do not support or hang load from load chain free end. Brake may not hold the load or operate correctly.**

Basic operating instructions for the L5H hoist are located on the capacity label attached to hand lever. Ensure capacity label is attached to hand lever. Refer to parts list for capacity label replacement part number. Refer to Dwg. MHP0589 on page 5.

Selector Lever Positions

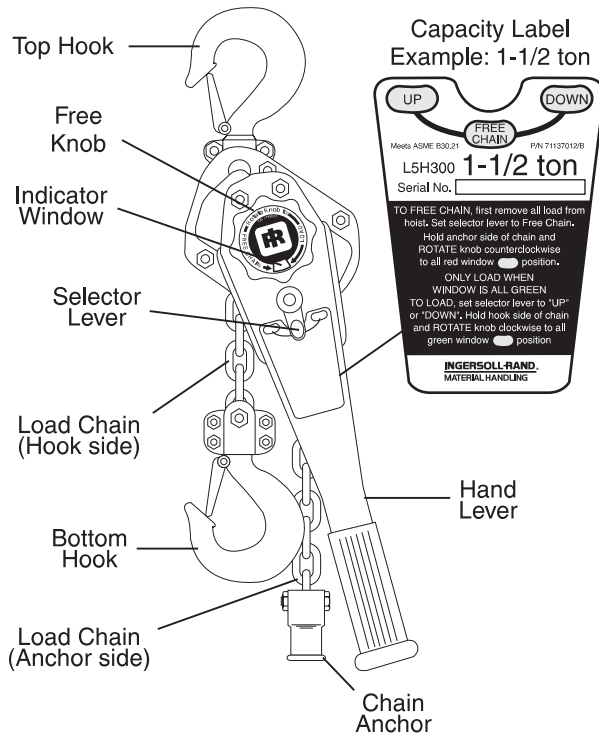

(Dwg. MHP0589)

Selector Lever Position	Hand Lever Rotation	Chain Movement
UP	Clockwise	Raise
FREE CHAIN	None*	Both*
DOWN	Counterclockwise	Lower

Refer to Dwg. MHP0589 on page 5.

* In the FREE CHAIN position, hand lever does not engage ratchet gear. Hand lever free-wheels until selector lever is shifted to the UP or DOWN position.

In the FREE CHAIN position chain may be raised (hailed in) by grasping anchor side of load chain and pulling or by turning free knob in the clockwise direction.

In the FREE CHAIN position chain may be lowered (payed out) by grasping hook side of load chain and pulling or by turning free knob in the counterclockwise direction.

Positioning Unloaded Hook (FREE CHAIN Position)

Refer to Dwg. MHP0589 on page 5.

Check that load chain anchor (41) is securely fastened in last link of free end of load chain. Load chain anchor is intended to prevent load chain from becoming disengaged from hoist and is not intended to support full load.

⚠ CAUTION

- **To prevent injury or property damage always remove load from hoist before shifting selector lever to FREE CHAIN position and/or rotating free knob to RED position.**
- **Ensure load is properly seated in saddle of bottom hook.**

1. Set selector lever to FREE CHAIN (center) position.
2. Grasp anchor side of load chain. Rotate free knob counterclockwise until all RED is viewed in indicator window of indicator plate.
3. Pull hook side of load chain to lower hook to desired location. Connect hook to load. Pull anchor side of load chain until chain slack is removed.

Lifting Load (UP position)

Refer to Dwg. MHP0589 on page 5.

The following procedure assumes hoist is in FREE CHAIN mode with all RED showing in the indicator window. The hook is attached to a load, but hoist is not supporting load.

⚠ WARNING

• **ALWAYS ensure that only all GREEN is viewed in the indicator window of indicator plate whenever shifting selector lever to the FREE CHAIN position to prevent dropping load. This includes shifting from the UP to DOWN, or DOWN to UP positions as the selector lever must pass through the FREE CHAIN position.**

1. Place selector lever in the UP position. Grasp the hook side of load chain.
2. Rotate free knob clockwise until all GREEN is viewed in indicator window of indicator plate.
3. Pull anchor end of load chain until slack is removed.
4. Rotate (ratchet) hand lever in **clockwise** direction to raise (haul in) load.

⚠ CAUTION

• **Ratchet may not engage and raise (UP) load until all chain slack is removed and hoist is supporting load weight. If hand lever movement does not produce lifting, apply tension to the anchor side of load chain while ratcheting until slack is removed and hoist begins lifting load. If hoist does not operate properly under load, remove load, inspect and repair hoist.**

• **The brake is engaged whether lowering or raising the load.**

Lowering Load (DOWN position)

Refer to Dwg. MHP0589 on page 5.

⚠ WARNING

• **Do not continue lowering hoist after chain anchor has contacted hoist body. Hoist damage may occur resulting in a falling load which can cause severe injury, death or property damage.**

The following procedure assumes the hoist selector lever is in the UP position and GREEN is showing in the indicator window. The hoist is holding a load and the operator wants to lower (pay out) the load:

1. Place selector lever in the DOWN position.
2. Rotate (ratchet) hand lever in the **counterclockwise** direction to lower (pay out) load.

⚠ CAUTION

• **To prevent injury or property damage always lower loads until load chain becomes slack before shifting to the FREE CHAIN position and/or rotating free knob to the RED position.**

Storing the Hoist

1. Always store the hoist in a no load condition.
2. Switch selector lever to FREE CHAIN (center position) and rotate free knob until all RED is viewed in the indicator window of indicator plate.
3. Wipe off all dirt and water.
4. Oil chain, hook pins and hook latch pins.
5. Hang in a dry place.
6. Before returning hoist to service follow instructions for Hoists not in Regular Service in the "INSPECTION" section.

INSPECTION

⚠ WARNING

• **All new, altered or modified equipment should be inspected and tested by personnel trained in safety, operation and maintenance of this equipment to ensure safe operation at rated specifications before placing equipment in service.**

Frequent and periodic inspections should be performed on equipment in regular service. Frequent inspections are visual examinations performed by operators or personnel trained in safety and operation of this equipment and include observations made during routine equipment operation. Periodic inspections are thorough inspections conducted by personnel trained in the safety, operation and maintenance of this equipment. ASME B30.21 states inspection intervals depend upon the nature of the critical components of the equipment and the severity of usage.

Careful inspection on a regular basis will reveal potentially dangerous conditions while still in the early stages, allowing corrective action to be taken before the condition becomes dangerous.

Deficiencies revealed through inspection, or noted during operation, must be reported to designated personnel trained in safety, operation and maintenance of this equipment. A determination as to whether a condition constitutes a safety hazard must be decided, and the correction of noted safety hazards accomplished and documented before placing equipment in service.

Records and Reports

Inspection records, listing all points requiring periodic inspection should be maintained for all load bearing equipment. Written reports, based on severity of service, should be made on the condition of critical parts as a method of documenting **periodic** inspections. These reports should be dated, signed by the person who performed the inspection, and kept on file where they are readily available for review.

Load Chain Reports

Records should be maintained documenting the condition of load chain removed from service as part of a long-range load chain inspection program. Accurate records will establish a relationship between visual observations noted during frequent inspections and actual condition of the load chain as determined by periodic inspection methods.

Frequent Inspection

The lever chain hoist should be inspected at the beginning of each shift. Visual inspections should also be conducted during regular service for any damage or evidence of malfunction which appears between regular inspections.

1. **OPERATION.** Check for visual signs or abnormal noises which could indicate a potential problem. Make sure hoist functions properly. Check chain feed through hoist and hook idler sheaves. If chain binds, jumps, or is excessively noisy or “clicks,” clean and lubricate the chain. If problem persists, the chain and load sheave may have to be replaced. Do not operate hoist until all problems have been determined and corrected.
2. **HOOKS.** Check for wear or damage, increased throat width, bent shank or twisting of hook. Replace hooks which exceed throat opening discard width (15%) shown in Table 1, refer to Dwg. MHP0040 on page 7, or exceed a 10° twist, refer to Dwg. MHP0111 on page 7. If the hook latch snaps past the tip of the hook, the hook is sprung and must be replaced. Check hook support bearings for lubrication and damage. Check hooks swivel easily and smoothly. Repair or lubricate as necessary.
3. **HOOK LATCHES.** Check the operation of hook latches. Replace if broken or missing.

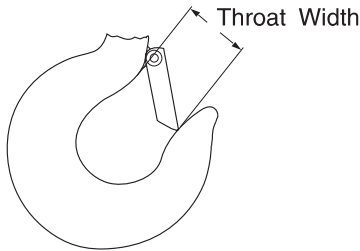

(Dwg. MHP0040)

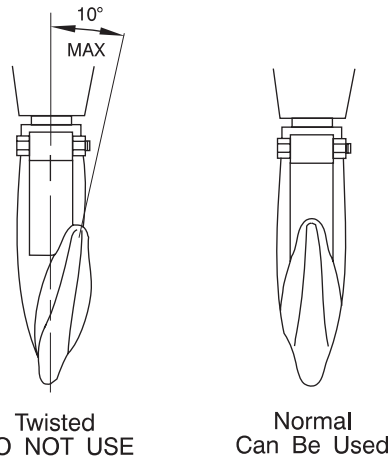

(Dwg. MHP0111)

Table 1: Hook Throat Width

Model Number	Throat Width		Discard Width	
	in.	mm	in.	mm
L5H150	1.22	31	1.4	35.7
L5H200				
L5H300	1.5	38	1.72	43.7
L5H400				
L5H600	1.85	47	2.12	53.8
L5H1200	2	51	2.31	58.7

4. **CHAIN.** Refer to Dwg. MHP0102 on page 7. Examine each link for bending, cracks in weld areas or shoulders, transverse nicks and gouges, weld splatter, corrosion pits, striation (minute parallel lines) and chain wear, including bearing surfaces between chain links. Replace a chain that fails any of the inspections. Check lubrication and lubricate if necessary. Refer to “Load Chain” in “LUBRICATION” section.

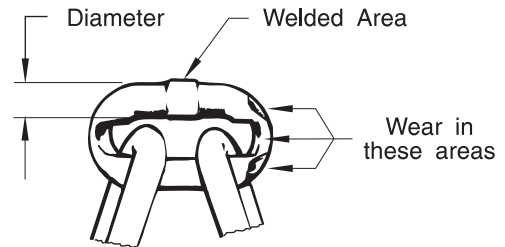

(Dwg. MHP0102)

⚠ CAUTION

- **The full extent of chain wear cannot be determined by visual inspection. At any indication of chain wear, inspect chain and load sheave in accordance with instructions in “Periodic Inspection.”**
 - **A worn load chain may cause damage to the load sheave. Inspect load sheave and replace if damaged or worn.**
5. **LOAD CHAIN REEVING.** Refer to Dwg. MHP0042 on page 9. Make sure welds on standing links are away from load sheave. Reinstall chain if necessary. Make sure chain is not capsized, twisted or kinked. Check that the chain stopper or anchor is in the end of the load chain. Adjust as required.
 6. **HAND LEVER.** Check for cracks, bending and other damage. Replace if necessary.

Periodic Inspection

According to ASME B30.21, frequency of periodic inspection depends on the severity of usage:

NORMAL	HEAVY	SEVERE
yearly	semi annually	quarterly

Disassembly may be required for HEAVY or SEVERE usage. Keep accumulative records of periodic inspections to provide a basis for continuing evaluation. Inspect all items in frequent inspection plus the following:

1. **FASTENERS.** Check rivets, capscrews, nuts, cotter pins and other fasteners on hooks and hoist body. Replace if missing and tighten or secure if loose.
2. **ALL COMPONENTS.** Inspect for wear, damage, distortion, deformation and cleanliness. If external evidence indicates the need, disassemble. Check gears, shafts, bearings, sheaves, chain guides, springs and covers. Replace worn or damaged parts. Clean, lubricate and reassemble.
3. **HOOKS.** Inspect hook retaining parts. Inspect hooks for cracks. Use magnetic particle or dye penetrant to check for cracks. Replace damaged parts. Refer to the latest edition of ASME B30.10 (Hooks) for additional hook inspection information.
4. **SHEAVES.** Check for excessive wear or damage. Replace if necessary.
5. **BRAKES.** Ensure proper operation. Brake should not slip with test load (rated capacity). If load test indicates the need, disassemble. Brake discs must be unglazed and uniform in thickness. Refer to "MAINTENANCE" section for allowable brake disc wear. Check all other brake surfaces for wear, deformation or foreign deposits. Inspect for damaged gear teeth, pawl and pawl spring. Check that pawl brake stops counterclockwise rotation of ratchet gear. Clean and replace damaged components as necessary.
6. **SUPPORTING STRUCTURE.** If a permanent structure is used, inspect for continued ability to support load.
7. **LABELS AND TAGS.** Check for presence and legibility. Replace if necessary.
8. **LOAD CHAIN.** Measure the chain for stretching by measuring across five link sections all along the chain. Refer to Dwg. MHP0041 on page 8. When any five links in the working length reach or exceed the discard length shown in Table 2, replace the entire chain. Always use a genuine **Ingersoll-Rand** replacement chain.
9. **END ANCHOR.** Inspect end anchor is securely attached to free end of load chain and check capscrew and nut are tightly fastened.

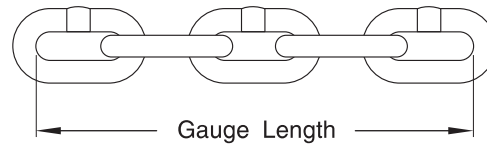

(Dwg. MHP0041)

Table 2: Load Chain Length Inspection

Model Number	Chain Size	Normal Length		Discard Length	
	mm	in.	mm	in.	mm
L5H150	6.3 x 19.2	3.76	95.5	3.85	97.9
L5H200					
L5H300	7.1 x 21.2	4.17	106	4.28	108.7
L5H400					
L5H600	9 x 27.2	5.35	136	5.49	139.4
L5H1200					

10. **OVERLOAD LIMIT CLUTCH** (optional feature). Ensure clutch prevents hoist from lifting loads greater than capacities listed in Table 3. Properly adjust and test overload limit clutch as described in the "MAINTENANCE" section.

Hoists Not in Regular Use

1. Hoists which have been idle for a period of one month or more, but less than one year shall be given an inspection conforming with the requirements of "Frequent Inspection" before being placed into service.
2. Hoists which have been idle for a period of over one year shall be given a complete inspection conforming with the requirements of "Periodic Inspection" before being placed into service.
3. Standby hoists shall be inspected at least semiannually in accordance with the requirements of "Frequent Inspection". If abnormal operating conditions apply hoists may require a more frequent inspection.

LUBRICATION

General

Thread lubricant or antiseize compound use is recommended for threaded shafts, capscrews and nuts. Unless otherwise stated, remove old lubricant, clean part with an acid free solvent and apply a new coating of lubricant to part before assembly.

Gears (11)

Remove nuts (13) on side of hoist opposite hand lever and remove gear cover (12). Remove old grease and replace with new. For temperatures -20° to 50° F (-29° to 10° C) use EP 1 grease or equivalent. For temperatures 30° to 120° F (-1° to 49° C) use EP 2 grease or equivalent.

Retainer Plate (74) and Support (75)

Lightly coat the mating surfaces between retainer plate (74) and support (75) with **Ingersoll-Rand** LUBRI-LINK-GREEN or equivalent to ensure free knob smoothly shifts from both **RED** to **GREEN** position and **GREEN** to **RED** position.

Load Chain

⚠ WARNING

• **Failure to maintain clean and well-lubricated load chain may result in chain failure and cause injury, death or damage to equipment.**

1. Lubricate each link of the chain weekly. Apply new lubricant over existing layer.
2. In severe applications or corrosive environments, lubricate more frequently than normal.
3. Lubricate hook and hook latch pivot points with same lubricant used on the load chain.
4. To remove rust or abrasive dust buildup, clean chain with an acid free solvent. After cleaning, lubricate the chain.
5. Use **Ingersoll-Rand** LUBRI-LINK-GREEN or a SAE 50 to 90W EP oil.

TROUBLESHOOTING

This section provides basic troubleshooting information. Specific causes to problems are best identified by thorough inspections performed by personnel instructed in safety, operation and maintenance of this equipment. The chart below provides a brief guide to common hoist symptoms, probable causes and remedies.

Symptom	Cause	Remedy
Hoist will not hold rated load.	Brake may be slipping.	Inspect and adjust or repair as described in the “INSPECTION” and “MAINTENANCE” sections.
Hoist will not lift load.	Overload Limit Clutch not adjusted properly.	Inspect and adjust or repair as described in the “INSPECTION” and “MAINTENANCE” sections.
	Excess slack in load chain.	Pull down on load chain while ratcheting until slack is removed and the hoist begins lifting the load. Refer to “OPERATION” section.
	Hoist is overloaded.	Reduce load to within rated capacity.
	Hoist is in FREE CHAIN mode.	Ensure GREEN is covering entire indicator window of indicator plate and selector lever is in UP position. Refer to “OPERATION” section.
Hoist will not FREE CHAIN.	Free knob may not be rotated fully.	Ensure RED is covering entire indicator window of indicator plate. Refer to “OPERATION” section.
Load Chain Binds.	Damaged load chain, pinion shaft, gears or sheaves.	Disassemble and inspect components as described in the “MAINTENANCE” and “INSPECTION” sections.
	Load chain not installed properly (twisted, kinked or “capsized”).	Inspect and adjust or repair as described in the “INSPECTION” and “MAINTENANCE” sections.
Load Hook Latch does not work.	Latch broken.	Replace hook latch.
	Load hook bent or twisted.	Inspect load hook as described in “INSPECTION” section. Replace if necessary.

MAINTENANCE

⚠ WARNING

- Never perform maintenance on the hoist while it is supporting a load.
- Before performing maintenance, tag hoist:
WARNING - DO NOT OPERATE - EQUIPMENT BEING REPAIRED
- Only allow personnel trained in the operation and service of this product to perform maintenance.
- After performing any maintenance on the hoist, test to 125% of its rated capacity before returning to service. (Testing to more than 125% of rated capacity might be required to comply with standards and regulations set forth in areas outside of the USA.)

Installing a New Load Chain

Refer to Dwg. MHP0042 on page 9.

1. Ensure welds of “standing” links on the new load chain are facing away from the load sheave (2).
2. Ensure load chain (35) is reeved between load sheave (2) and chain guides (5).
3. Bottom hook assembly (36) must be on left fall of load chain (35) and right fall must have an anchor (41) attached to the end link.

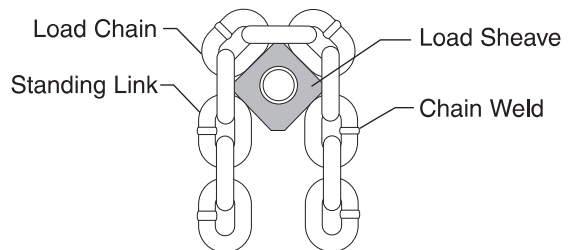

(Dwg. MHP0042)

NOTICE

- Right and left are designated as viewed from the hand lever side of the hoist.
4. Load chain on 6 ton hoists feeds through the bottom block assembly and secures to top hook bracket. Ensure load chain is straight and not twisted. Chain weld on standing links will be to the inside of bottom hook idle sheave (46). Refer to Dwg. MHP0590 on page 10.
 5. Lubricate new load chain before using hoist. Refer to “LUBRICATION” section for recommended lubricants.

Brake Adjustment

Refer to Dwg. MHP0645 on page 16.

1. Remove the retainer ring (70), indicator plate (72), pinion nut (34), support (75), retainer plate (74), spring (33), free knob (32) and check (50).
2. Attach a load to the lower hook.
3. Adjust and remove the chain slack.
4. Switch selector lever to UP.
5. Rotate (ratchet) hand lever (33) clockwise until load is applied to the chain.

L5H 6 ton Hoist Chain Installation

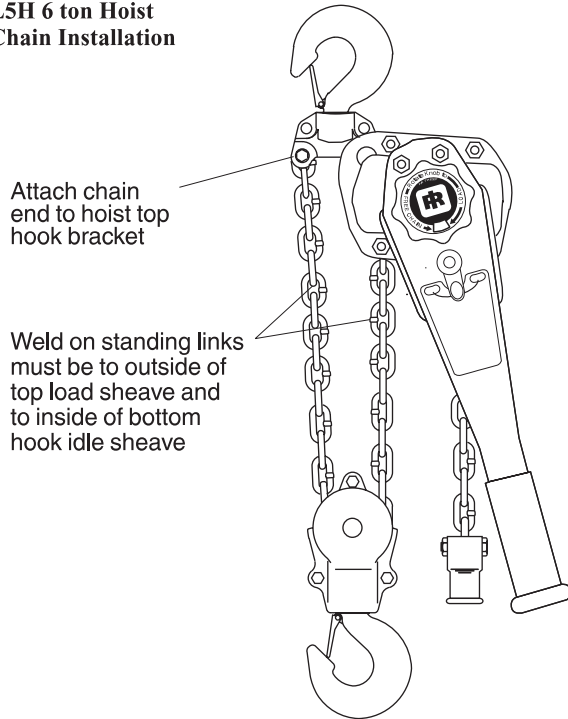

(Dwg. MHP0590)

NOTICE

- Rotating pinion shaft (3) counterclockwise also tightens the brake.
- The hand lever must fit tight up against the brake cover (20).

6. Install tension spring (29) in change gear (26) and locate in the wide side of dividers as shown in Dwg. MHP0591 on page 10.
7. Align splines of check (50) and pinion shaft (3) such that check (50) projection touches the tension spring (29) as shown in Dwg. MHP0591 on page 10.
8. Install free knob (32) such that the projection of the free knob is located in the narrow side of change gear (26) dividers.
9. Install the retainer plate (74), support (75), and pinion nut (34). Tighten pinion nut.
10. Place selector lever in DOWN position. Rotate free knob clockwise.
11. Raise load, and operate hoist as described in the "OPERATION" section to test brake. Ensure hoist holds load in both the UP and DOWN selector lever positions.
12. Adjust change gear on pinion shaft until hoist properly operates in both loaded and free chain modes. Install indicator plate (72) and retainer ring (70).

NOTICE

- After installing pinion nut (34), the hand lever should be flush against the brake cover (20). If the pinion shaft (3) rotates while pinion nut (34) is being installed, reinstall hand lever and repeat brake adjustment procedure.

Assembly Alignment Diagram

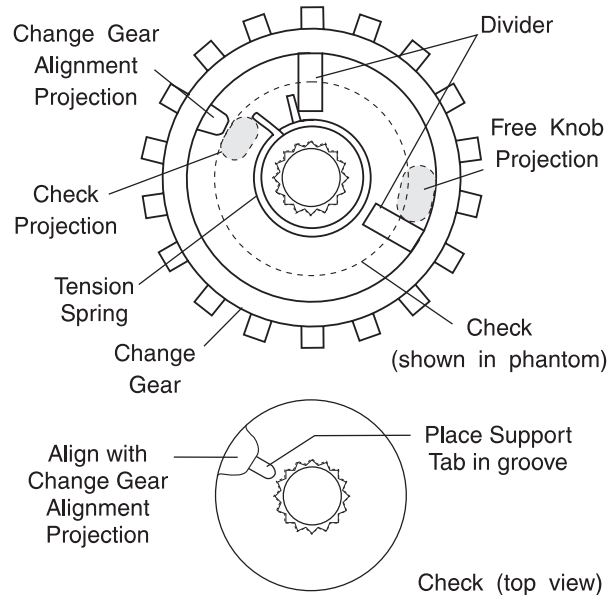

(Dwg. MHP0591)

Overload Limit Clutch Adjustment (optional feature)

Refer to Dwg. MHP0645 on page 16.

1. Hang the hoist from an appropriate support and attach a test load equal to 150% of rated hoist capacity to the lower hook.
2. Remove the retainer ring (70), indicator plate (72), pinion nut (34), support (75), retainer plate (74), spring (33), free knob (32) and check (50).
3. Using special adjustment tool (Part Number 71112064), adjust nut (55) until hoist will lift test load **without** slipping. Refer to Table 3 to determine test load. Raise load approximately 2 inches (51 mm).

NOTICE

- Overload limit clutch proper adjustment requires the use of a special tool (Part Number 71112064). Refer to Dwg. MHP0225 on page 10.

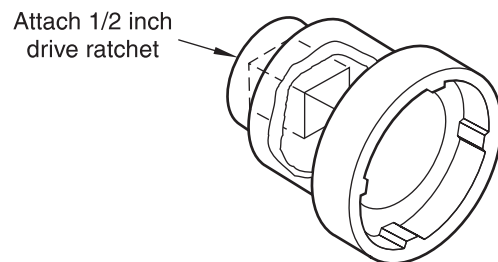

(Dwg. MHP0225)

Table 3: Overload Limit Clutch Test Loads

Model No.	Adjustment Load (150% of rated load)	
	lbs.	kgs.
L5H150-V	2,475	1,125
L5H200-V	3,000	1,364
L5H300-V	4,950	2,250
L5H400-V	6,000	2,727
L5H600-V	9,900	4,500
L5H1200-V	19,800	9,000

4. Using special adjustment tool, loosen nut (55) in small increments. Operate ratchet handle. When properly adjusted the ratchet handle will rotate, but the load will not raise. When this occurs, shift the selector lever to the “DOWN” position and lower load.
5. When the desired overload limit has been set, bend one of the outer tabs on washer (54) into grooved slot in nut (55).
6. Install check (50), free knob (32), spring (33), retainer plate (74), support (75), pinion nut (34), indicator plate (72), and retainer ring (70).

General Disassembly

The following instructions provide the necessary information to disassemble, inspect, repair, and assemble the hoist. Parts drawings of the hoist assembly are provided in the Parts Section.

If a hoist is being completely disassembled for any reason, follow the order of the topics as they are presented. It is recommended that all maintenance work on the hoist be performed on a bench in a clean dust free area.

In the process of disassembling the hoist, observe the following:

1. Never disassemble the hoist any further than is necessary to accomplish the needed repair. A good part can be damaged during the course of disassembly.
2. Never use excessive force when removing parts. Tapping gently around the perimeter of a cover or housing with a soft hammer, for example, is sufficient to break the seal.
3. Do not heat a part with a flame to free it for removal unless the part being heated is already worn or damaged beyond repair and no additional damage will occur to other parts. In general, the hoist is designed to permit easy disassembly and assembly. Use of heat or excessive force should not be required.
4. Keep the work area as clean as practical, to prevent dirt and other foreign matter from getting into bearings or other moving parts.
5. When grasping a part in a vise, always use leather-covered or copper-covered vise jaws to protect the surface of the part and help prevent distortion. This is particularly true of threaded members, machined surfaces and housings.
6. Do not remove any part which is press fit in or on a subassembly unless the removal of that part is necessary for repairs or replacement.

Hoist Disassembly

Refer to Dwgs. MHP0586 on page 14 and MHP0645 on page 16.

Disc Brake Replacement

To remove brake discs (18), disassemble the hoist using the following procedure:



• **When removing pinion nut (34), apply pressure to support (75) to prevent spring (33) from uncontrolled release resulting in injury.**

1. Remove the retainer ring (70), indicator plate (72), pinion nut (34), support (75), retainer plate (74), spring (33), free knob (32), check (50) and tension spring (29).
2. Remove bolts (31) and U-nuts (30) and separate hand lever (23) from brake cover assembly (20). The change pawl (25), push pin (28) and push spring (27) should be removed from the hand lever for cleaning and to prevent accidental loss.
3. Remove change gear (26).
4. For hoists **with** overload limit clutch only: Grip the outside diameter of change gear (26) and unscrew overload limit clutch as an assembly.
5. Remove U-nuts (13) and separate brake cover (20) from side plate (1).
6. Remove brake ring (21), brake discs (18) and ratchet gear (19).

Overload Limit Clutch Disassembly

1. Refer to ‘Disc Brake Replacement’ section for removal of overload limit clutch assembly.
2. Use a small punch to bend tab on washer (54) out of groove in nut (55).
3. Firmly grip outside of overload limit clutch assembly and, using special adjustment tool (Part Number 71112064), remove nut (55) from support (51). Be careful to collect the spring (76) and ball (77), located between support and change gear (26), as pressure is released during nut removal.
4. Separate the remaining parts of assembly.

Accessing Gear End

1. Remove four nuts (13) and pry gear cover (12) from side plate 2 (7).
2. Remove 2nd and 3rd gears (11) and 1st gear (10).

Accessing Load Sheave (2)

Follow steps 1 through 5 under “Hoist Disassembly” ‘Disc Brake Replacement’ section and steps 1 and 2 of the ‘Accessing Gear End’ section. Additionally, perform the following:

1. Pry side plate 2 (7) from hoist assembly.
2. Remove top hook (8), the two load chain guides (5) and chain stripper (6).
3. Remove load chain (35).
4. Remove snap rings (17), brake pawls (16) and brake springs (15) from side plate 1 (1).
5. Unscrew hub (14) from pinion shaft (3). Remove pinion shaft. Remove load sheave (2) from pinion shaft.

Cleaning and Inspection

Use the following procedures to clean and inspect the components of the hoist.

Cleaning

Clean all hoist component parts in solvent (except for the brake discs). The use of a stiff bristle brush will facilitate the removal of accumulated dirt and sediments on the gears and frames. Dry each part using low pressure, filtered compressed air. If the brake discs are oil soaked, they must be replaced.

Inspection

All disassembled parts should be inspected to determine their fitness for continued use. Pay particular attention to the following:

1. Inspect all gears for worn, cracked, or broken teeth.
2. Inspect shafts for ridges caused by wear. If ridges caused by wear are apparent on shafts, replace the shaft.
3. Inspect all threaded items and replace those having damaged threads.
4. Inspect the brake discs for oil. If the brake discs are oil-soaked, replace the brake discs.
5. Measure the thickness of the brake discs. Refer to Table 4 to determine discard thickness.

Table 4: Brake Disc Thickness Chart

Model	New Disc Thickness		Discard Thickness		Color
	inch	mm	inch	mm	
L5H	0.076	3	0.064	2.5	Dark Grey

Hoist Assembly

Refer to Dwg. MHP0586 on page 14.

CAUTION

- **The brake will not operate properly if there is oil or grease on the brake discs (18).**
- **The brake cover (20) can be installed improperly. The outer edges of the brake cover (20) and side plate 1 (1) must match.**

Follow steps 1 through 8 described in 'Load Sheave Assembly' section. Additionally, perform the following:

1. Brake discs must remain dry and free from oil and grease.
2. Install new brake disc (18), ratchet gear (19) and brake ring (21) on hub (14). Check brake pawls (16) are spring loaded to engage ratchet gear (19) and ratchet gear turns freely.
3. Install brake cover assembly (20) on side plate (1) and secure with nuts (13). Install second brake disc (18).
4. Install change gear (26). Carefully rotate change gear (26) until tabs locate in brake ring (21).
5. Install push spring (27), push pin (28) and change pawl (25) on hand lever (23). Ensure selector lever is in the free chain (center) position. Install hand lever on brake cover (20) and secure with bolts (31) and U-nuts (30).
6. Move change gear to UP position. Insert a screwdriver blade or short rod through one of the **hook side** chain links near the side plates (1 and 7), or suspend a light load from the hook.

7. Install tension spring (29). Align check (50) tab with small tab on change gear (26) and install check (50) on spline of pinion shaft (3). Using a small blade screw driver, or similar tool, place tension spring as shown in Dwg. MHP0591 on page 10.
8. Install tab of free knob (32) in narrow area of change gear (26). Refer to Dwg. MHP0591 on page 10.
9. Check for proper alignment of the support (75) and indicator plate (72). Place the support in free knob (32). Align tab on support to fit in groove of check (50). Align tabs on indicator plate and view plate with groove in free knob. For proper alignment the view window must locate on the support such that the green and red colors will be viewed through the window. Note orientation and remove support and indicator plate.

CAUTION

- **Ensure tab on support (75) properly aligns with groove in check (50) before tightening nut (34) to prevent damage.**

10. Lightly coat mating surfaces between retainer plate (74) and support (75) with **Ingersoll-Rand LUBRI-LINK-GREEN** or equivalent lubricant and install adjusting spring (33), retainer plate, and support. Adjust support until tab engages in groove on check (50). Secure in position with pinion nut (34).
11. Install indicator plate (72) and retainer ring (70).

NOTICE

- **Ensure hoist will properly shift from UP, DOWN and FREE CHAIN positions using the selector lever. With selector lever in FREE CHAIN (center) position, and ONLY RED showing in the indicator window of the indicator plate, ensure brake disengages and load chain can be pulled in both directions without sticking or binding.**

Gear End Assembly

Follow steps 1 through 5 described in 'Load Sheave Assembly' section. Additionally, perform the following:

1. Install 1st gear (10) on splines of load sheave (2).
2. Install 2nd and 3rd gears (11) so gear teeth are correctly meshed with 1st gear and spigots locate in bearing sleeves in side plate 2 (7).
3. Apply a thick coat of lubricant recommended in "LUBRICATION" section to gears. Install gear cover (12) on side plate 2 (7) and secure with U-nuts (13).

Load Sheave Assembly

1. Install load sheave (2) and load chain (35) on side plate 1 (1). Ensure load chain welds face away from load sheave. Install load chain with bottom hook fall on the left as viewed from the lever side of the hoist.
2. Install chain stripper (6) in slot in side plate 1 (1) with tab projection toward load sheave (2).
3. Install chain guides (5), hook pin (9) and top hook (8) assembly.
4. Carefully install side plate 2 (7) ensuring all parts are located in their respective bores and slots.
5. Lubricate non-threaded portion of pinion shaft (3) and insert through load sheave (2) bore from gear side of hoist.
6. Follow steps 2 through 4 described in 'Gear End Assembly' section.

7. Screw hub (14) fully onto pinion shaft (3) threaded section.
8. Install brake springs (15) and brake pawls (16) to side plate 1 (1) (hoist lever side). Secure with snap rings (17).
9. Follow steps 2 through 11 described in 'Brake Adjustment' section.

Overload Limit Clutch Assembly

Refer to Dwg. MHP0645 on page 16.

⚠ CAUTION

- **Ensure brake disc (18), and mating surfaces of support (51) and hub (14) are clean. Do not lubricate.**
- **Ensure tab on support (75) properly aligns with groove in check (50) before tightening nut (34) to prevent damage.**

1. Lightly coat spring (76) and ball (77) using **Ingersoll-Rand LUBRI-LINK-GREEN** or equivalent lubricant and position in hole on support (51). Align grooves on change gear (26) such that the ball and spring are centered between two of the grooves. Change gear tabs must be located such that they are facing away from support.
2. Lightly coat cone wheel (52) using **Ingersoll-Rand LUBRI-LINK-GREEN** or equivalent lubricant and install in support (51). Ensure cone wheel tabs engage with change gear (26) grooves.
3. Coat cone spring (53) using **Ingersoll-Rand LUBRI-LINK-GREEN** or equivalent lubricant and install with dished surface towards change gear (26).
4. Install washer (54) on hub of change gear (26). Locate tab of washer in change gear groove. Outer tabs of washer must angle away from cone spring (53).
5. Install nut (55) on support (51). Hand tighten enough to firmly hold parts in position. Install in hoist with support (51) placed against brake disc.
6. Align tab on check (50) and install on pinion shaft (3) splines such that the tab is centered in one of the grooves (between tabs) on change gear (26).
7. Align tab on free knob (32) and install. Ensure the tab is located in a different groove than the check (50) tab.
8. Check for proper alignment of the support (75) and indicator plate (72). Place support in free knob (32). Align tab on support to fit in groove of check (50). Align tabs on indicator plate and view plate with groove in free knob. For proper alignment the view window must locate on the support such that the green and red colors will be viewed through the window. Note orientation and remove support and indicator plate.
9. Lightly coat mating surfaces between retainer plate (74) and support (75) with **Ingersoll-Rand LUBRI-LINK-GREEN** or equivalent lubricant and install adjusting spring (33), retainer plate, and support. Adjust support until tab engages in groove on check (50). Secure in position with pinion nut (34).
10. Install indicator plate (72) and retainer ring (70).

NOTICE

- **Ensure the hoist will properly shift from UP, DOWN and FREE CHAIN positions using the selector lever. With selector lever in the FREE CHAIN (center) position, and GREEN showing in the indicator window of the indicator plate, ensure brake disengages and that the load chain can be pulled in both directions without sticking or binding.**

11. Install assembly on hoist and adjust as described in the 'Adjustments' section.

Testing

Overload Limit Clutch Test (optional feature)

Prior to load testing, adjust and test the overload limit clutch as described in 'Overload Limit Clutch Adjustments' in the "MAINTENANCE" section.

Load Test

Prior to initial use, all new, extensively repaired, or altered hoists shall be load tested by or under the direction of a person trained in safety, operation and maintenance of this hoist, and a report furnished confirming the rating of the hoist. Test hoist to 125% of the rated hoist capacity. Testing to more than 125% is required to verify overload clutch operation and may be necessary to comply with standards and regulations set forth in areas outside of the USA.

L5H HOIST ASSEMBLY DRAWING

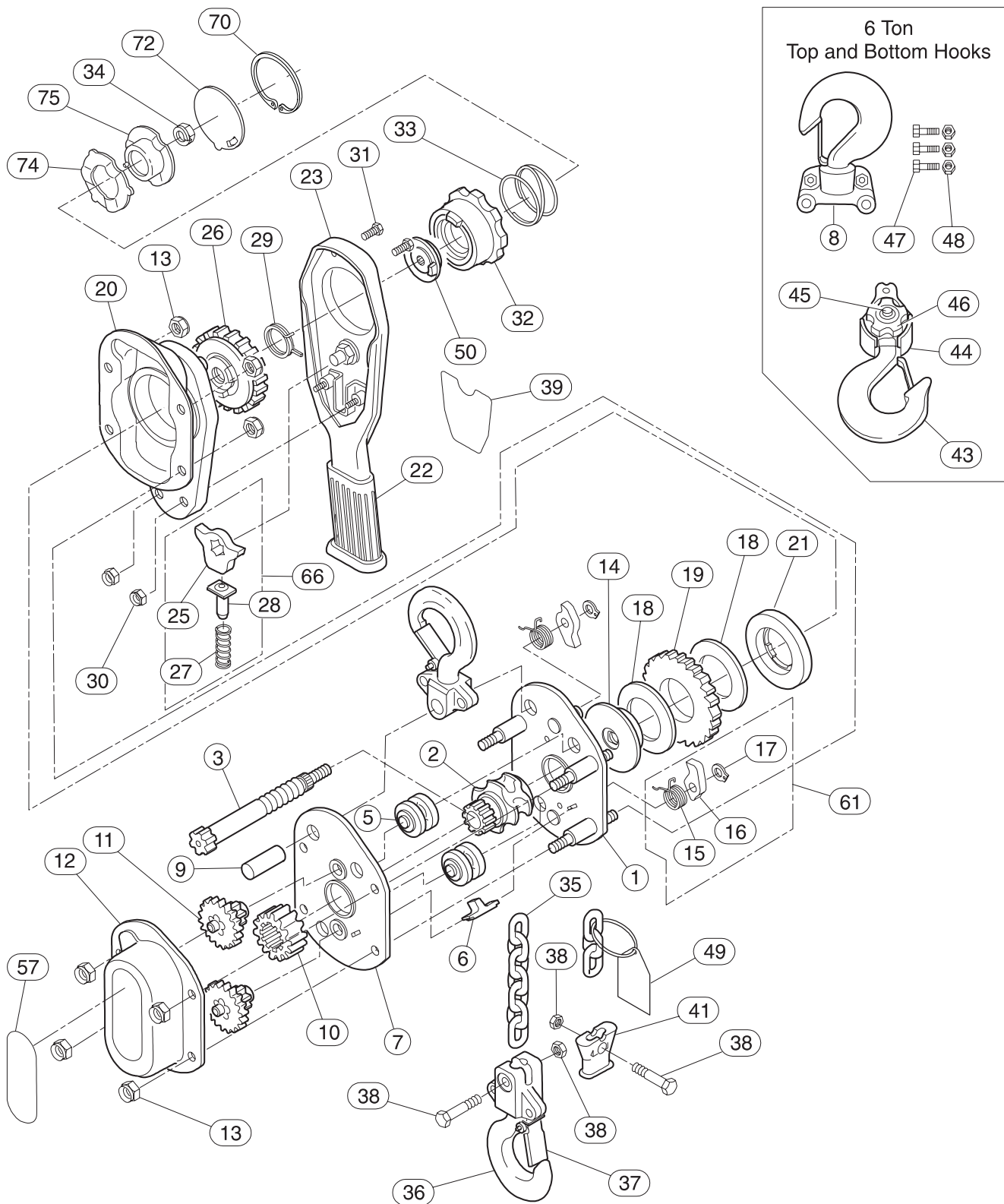

(Dwg. MHP0586)

L5H HOIST PARTS LIST

ITEM NO.	DESCRIPTION OF PART	QTY. TOTAL	PART NO.						
			3/4 ton	1 ton	1-1/2 ton	2 ton	3 ton	6 ton	
1	Side Plate 1	1	71076012		71076020		71076038		
2	Load Sheave	1	71076046		3573142		3573143		
3	Pinion Shaft	1	71076327		71076335		71076343		
5	Load Chain Guide	2	3372352		3372393		3372414		
6	Chain Stripper	1	3372353		3372394		3372415		
7	Side Plate 2	1	3573154		3573155		3573156		
• 8	Top Hook Assembly	1	3372354	71062723	3372395	71062749	3372416	3372439	
9	Hook Pin	1	71076111		71076129		71076137		
10	1st Gear	1	3372356		3372397		3372418		
11	2nd and 3rd Gear	1 set	71490247		71490254		71490262		
12	Gear Cover	1	71076087		71076095		71076103		
13	U-Nut	1 set	Order Fastener Kit item 62						
14	Hub	1	71076160		71076178		71490262		
15	Brake Spring	1 set	Order Brake Pawl Kit item 61						
16	Brake Pawl								
17	Snap Ring								
• 18	Brake Disc	1 set	71079594				71079602		
19	Ratchet Gear	1	3372370				3372432		
20	Brake Cover Assy	1	71076228		71076236		71076244		
21	Brake Ring	1	71076350				71076368		
22	Grip	1	3573179		3372442				
23	Hand Lever	1	3372374		3372404				
25	Change Pawl	1	Order Change Pawl Kit item 66						
26	Change Gear	1	71137335		71137343				
27	Push Spring	1 set	Order Change Pawl Kit item 66						
28	Push Pin								
29	Tension Spring	1	71137327						
30	U-Nut	1 set	Order Fastener Kit item 62						
31	Capscrew								
32	Free Knob	1	71137293						
33	Spring	1	71137277				71137285		
34	Pinion Nut	1	71137244						
35	Load Chain	1	Refer to "LOAD CHAIN" Table						
• 36	Bottom Hook Assy	1	L5H150-BHK	L5H200-BHK	L5H300-BHK	L5H400-BHK	L5H600-BHK	3372440	
• 37	Hook Latch	2	71489249	71489256	71489264	71489272	3372437	3372373	
38	Bolt and Nut	2	3372388		71144521		3372438	---	
39	Capacity and Serial No. Label	1	71136998	71137004	71137012	71137020	71137038	71137046	
41	Anchor	1	Order Anchor Kit item 60						
• 43	Bottom Hook	1	---						71076293
44	Bottom Frame	2	---						2372946
45	Axle	1	---						71076301
46	Idle Sheave	1	---						71076319
47	Yolk Bolt	1 set	---						*
48	U-Nut								
49	Warning Tag	1	71053599						
50	Check	1	71137301			71137319			
57	Capacity Label	1	71136931	71136949	71136956	71136964	71136972	71136980	
70	Retainer Ring	1	71137210						
72	Indicator Plate	1	71489629						
74	Retainer Plate	1	71137269						
75	Support	1	71137251						
•	Recommended Spare		* Order Yoke Bolt and Nut Kit item 65						

L5H HOIST WITH OVERLOAD LIMIT CLUTCH ASSEMBLY DRAWING

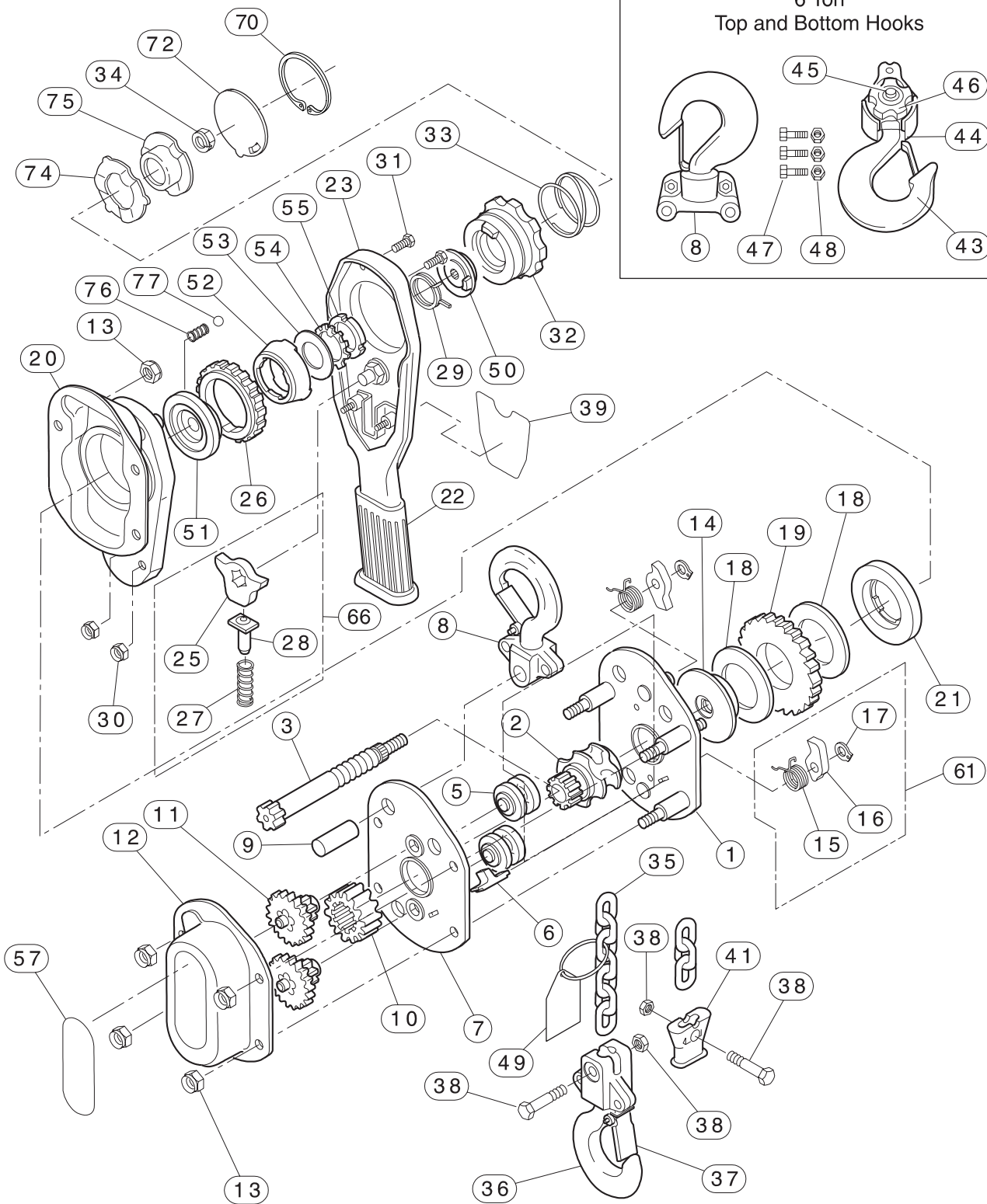

(Dwg. MHP0645)

L5H HOIST WITH OVERLOAD LIMIT CLUTCH ASSEMBLY PARTS LIST

ITEM NO.	DESCRIPTION OF PART	QTY. TOTAL	PART NO.						
			3/4 ton	1 ton	1-1/2 ton	2 ton	3 ton	6 ton	
1	Side Plate 1	1	71076012		71076020		71076038		
2	Load Sheave	1	71076046		3573142		3573143		
3	Pinion Shaft	1	71076327		71076426		71076434		
5	Load Chain Guide	2	3372352		3372393		3372414		
6	Chain Stripper	1	3372353		3372394		3372415		
7	Side Plate 2	1	3573154		3573155		3573156		
• 8	Top Hook Assembly	1	3372354	71062723	3372395	71062749	3372416	3372439	
9	Hook Pin	1	71076111		71076129		71076137		
10	1st Gear	1	3372356		3372397		3372418		
11	2nd and 3rd Gear	1 set	71490247		71490254		71490262		
12	Gear Cover	1	71076087		71076095		71076103		
13	U-Nut	1 set	Order Fastener Kit item 62						
14	Hub	1	71076160		71076178		71076186		
15	Brake Spring	1 set	Order Brake Pawl Kit item 61						
16	Brake Pawl								
17	Snap Ring								
• 18	Brake Disc	1 set	71079594				71079602		
19	Ratchet Gear	1	3372370				3372432		
20	Brake Cover Assy	1	71076228		71076236		71076244		
22	Grip	1	3573179		3372442				
23	Hand Lever	1	3372374		3372404				
25	Change Pawl	1	Order Change Pawl Kit item 66						
26	Change Gear	1	71148365						
27	Push Spring	1 set	Order Change Pawl Kit item 66						
28	Push Pin								
30	U-Nut	1 set	Order Fastener Kit item 62						
31	Capscrew								
32	Free Knob	1	71148415						
33	Spring	1	71148332						
34	Pinion Nut	1	71137244						
35	Load Chain	1	Refer to "LOAD CHAIN" Table						
• 36	Bottom Hook Assy	1	L5H150-BHK	L5H200-BHK	L5H300-BHK	L5H400-BHK	L5H600-BHK	3372440	
• 37	Hook Latch	2	71489249	71489256	71489264	71489272	3372437	3372373	
38	Bolt and Nut	2	3372388		71144521		3372438	---	
39	Capacity and Serial No. Label	1	71148571	71148589	71148597	71148605	71148613	71148621	
41	Anchor	1	Order Anchor Kit item 60						
• 43	Bottom Hook	1	---						71076293
44	Bottom Frame	2	---						2372946
45	Axle	1	---						71076301
46	Idle Sheave	1	---						71076319
47	Yolk Bolt	1 set	---						*
48	U-Nut								
49	Warning Tag	1	71053599						
50	Check	1	71076517						
51	Support	1	71148399				71148407		
52	Cone Wheel	1	71076475						
53	Cone Spring	1	71148357						
54	Washer	1	71148340						
55	Nut	1	71076509						
57	Capacity Label	1	71136931	71136949	71136956	71136964	71136972	71136980	
70	Retainer Ring	1	71137210						
•	Recommended Spare.		* Order Yoke Bolt and Nut Kit item 65.						

ITEM NO.	DESCRIPTION OF PART	TOTAL QTY.	PART NO.				
			3/4 ton	1 ton	1-1/2 ton	2 ton	3 ton

L5H Hoist with Overload Limit Clutch Assembly

72	Indicator Plate	1	71137228				
74	Retainer Plate	1	71137269				
75	Support	1	71137251				
76	Spring	1	71148381				
77	Ball	1	71148373				
78	Overload Clutch Label	1	71137053				

Load Chain

35	Load Chain (Standard)	**	LCCF010	LCCF015	LCCF025
	Load Chain* (Zinc Plated)		LCCF010ZP	LCCF015ZP	LCCF025ZP
	Load Chain (Nickel Diffused)		LCCF010ND	LCCF015ND	LCCF025ND

* Zinc plated load chain available in European market only.

** Load chain sold by length of lift in feet. Specify required length of lift in feet.

Assemblies and Kits

60	Anchor Assembly (Incl's items 38 and 41)	71046965	71046973
61	Brake Pawl Kit (Incl's items 15, 16 and 17)	71079529	71079537
62	Fastener Kit (Incl's items 13, 30 and 31)	71079313	
65	Yoke Bolt and Nut Kit (Incl's items 47 and 48)	—	71079255
66	Change Pawl Kit (Incl's items 25, 27 and 28)	71079545	

Accessories

Lubricant	LUBRI-LINK-GREEN
Overload Limit Clutch Adjustment Tool	71112064

PARTS ORDERING INFORMATION

The use of other than genuine **Ingersoll-Rand** replacement parts may adversely affect the safe operation of this product.

For your convenience and future reference it is recommended that the following information be recorded.

Hoist Model Number: _____

Hoist Serial Number: _____

Date Purchased: _____

When ordering replacement parts, please specify the following:

1. Complete model number and serial number as it appears on the nameplate.
2. Part number(s) and part description as shown in this manual.
3. Quantity required.
4. Standard or Overload Limit Clutch hoist version. (Overload clutch model hoists contain a "V" designation on the nameplate.)

Capacity and serial number nameplate for L5H Hoists is located on the hand lever, under the selector lever. Capacity and serial number nameplate shown is for 1-1/2 ton L5H Hoist, model L5H300.



Capacity label is located on gear cover. Capacity label shown is for 1-1/2 ton L5H hoist, model L5H300.



NOTICE

• Continuing improvement and advancement of design may cause changes to this equipment which are not included in this manual. Manuals are periodically revised to incorporate changes. Always check the manual edition number on the front cover for the latest issue.

Disposal

When the life of the hoist has expired, it is recommended that the hoist be disassembled, degreased and parts separated as to materials so that they may be recycled.

Return Goods Policy

Ingersoll-Rand will not accept any returned goods for warranty or service work unless prior arrangements have been made and written authorization has been provided from the location where the goods were purchased.

Hoists returned with opened, bent or twisted hooks, or without chain and hooks, will not be repaired or replaced under warranty.

WARRANTY

Limited Warranty

Ingersoll-Rand Company (**I-R**) warrants to the original user its Hoists and Winches (Products) to be free of defects in material and workmanship for a period of one year from the date of purchase. **I-R** will repair, without cost, any Product found to be defective, including parts and labor charges, or at its option, will replace such Products or refund the purchase price less a reasonable allowance for depreciation, in exchange for the Product. Repairs or replacements are warranted for the remainder of the original warranty period.

If any Product proves defective within its original one year warranty period, it should be returned to any Authorized Hoist and Winch Service Distributor, transportation prepaid with proof of purchase or warranty card.

This warranty does not apply to Products which **I-R** has determined to have been misused or abused, improperly maintained by the user, or where the malfunction or defect can be attributed to the use of non-genuine **I-R** parts.

I-R makes no other warranty, and all implied warranties including any warranty of merchantability or fitness for a particular purpose are limited to the duration of the expressed warranty period as set forth above. I-R's maximum liability is limited to the purchase price of the Product and in no event shall I-R be liable for any consequential, indirect, incidental, or special damages of any nature rising from the sale or use of the Product, whether based on contract, tort, or otherwise.

Some states do not allow limitations on incidental or consequential damages or how long an implied warranty lasts so that the above limitations may not apply to you.

This warranty gives you specific legal rights and you may also have other rights which may vary from state to state.

Important Notice

It is our policy to promote safe delivery of all orders.

This shipment has been thoroughly checked, packed and inspected before leaving our plant and receipt for it in good condition has been received from the carrier. Any loss or damage which occurs to this shipment while enroute is not due to any action or conduct of the manufacturer.

Visible Loss or Damage

If any of the goods called for on the bill of lading or express receipt are damaged or the quantity is short, do not accept them until the freight or express agent makes an appropriate notation on your freight bill or express receipt.

Concealed Loss or Damage

When a shipment has been delivered to you in apparent good condition, but upon opening the crate or container, loss or damage has taken place while in transit, notify the carrier's agent immediately.

Damage Claims

You must file claims for damage with the carrier. It is the transportation company's responsibility to reimburse you for repair or replacement of goods damaged in shipment. Claims for loss or damage in shipment must not be deducted from the **Ingersoll-Rand** invoice, nor should payment of **Ingersoll-Rand** invoice be withheld awaiting adjustment of such claims as the carrier guarantees safe delivery.

You may return products damaged in shipment to us for repair, which services will be for your account and form your basis for claim against the carrier.

United States Office Locations

For Order Entry and Order Status

**Ingersoll-Rand
Distribution Center**
P.O. Box 618
510 Hester Drive
White House, TN 37188
Phone: (615) 672-0321
Fax: (615) 672-0801

Web Site:
www.irco.com

Regional Sales Offices

Annandale, NJ
P.O. Box 970
1467 Route 31 South
Annandale, NJ 08801
Phone: (908) 238-7000
Fax: (908) 238-7048

Detroit, MI
1872 Enterprise Drive
Rochester, MI 48309
Phone: (248) 293-5700
Fax: (248) 293-5800

International Office Locations

Offices and distributors in principal cities throughout the world. Contact the nearest **Ingersoll-Rand** office for the name and address of the distributor in your country or write/fax to:

Canada

National Sales Office Regional Warehouse Toronto, Ontario

51 Worcester Road
Rexdale, Ontario
M9W 4K2
Phone: (416) 213-4500
Fax: (416) 213-4510

Order Desk
Fax: (416) 213-4506

Latin America Operations Ingersoll-Rand

730 N.W. 107 Avenue
Suite 300, Miami, FL, USA
33172-3107
Phone: (305) 559-0500
Fax: (305) 222-0864

Europe, Middle East and Africa

Douai Operations
111, avenue Roger Salengro
59450 Sin Le Noble, France
Phone: (33) 3-27-93-08-08
Fax: (33) 3-27-93-08-00

Asia Pacific Operations Ingersoll-Rand

42 Benoi Road
Jurong, Singapore 629903
Phone: 65-861-1555
Fax: 65-861-0317

Russia

Ingersoll-Rand
Kuznetsky Most 21/5
Entrance 3
Moscow 103895 Russia
Phone: 7-501-923-9134
Fax: 7-501-924-4625

Australia

Ingersoll-Rand Aust
1 Hartnett Drive
Seaford, Vic 3198
Australia
Phone: 613 95541642
Fax: 613 95541607